



## **SR3017 *Trident* Acoustic Receiver, Shore-based User Manual**

Version 5.00

Advanced Telemetry Systems, Inc.  
470 First Avenue NW  
Isanti, MN 55040  
763-444-9267  
[www.atstrack.com](http://www.atstrack.com)

## TABLE OF CONTENTS

1.0 FUNCTIONALITY .....	4
2.0 START-UP AND LED SEQUENCES .....	6
3.0 DATA FILE FORMAT .....	9
3.1 Header Format .....	10
3.2 Data Format .....	11
<b><u>4.0 H2O TRIDENT SERIES USB INTERFACE AND FILTER SOFTWARE</u></b> .....	<b>12</b>
4.1 Main Command Window .....	12
4.2 Edit Configuration .....	14
4.3 View Real Time Logging .....	15
4.4 GPS Data Tagging for Mobile Tracking .....	19
4.5 Filter Data .....	21
<b>4.5.1 Standard JSAT's Coded Tags</b> .....	<b>22</b>
4.5.2 Temperature and Depth Tags .....	22
4.5.2.1 Sensor Tag Code List .....	22
4.5.2.2 Barometric Pressure .....	23
4.5.2.3 Temperature Only Tags .....	24
5.0 FILTER DATA FILE FORMAT .....	26
5.1 Filter File Output Type 1 .....	26
5.2 Filter File Output Type 2 .....	27
5.3 Filter File Output Type 3 .....	30
5.4 Filter File Output Type 4 .....	31
5.5 Filter File Output Type 5 .....	31
5.6 Additional Output for Temperature and Depth Tags .....	33
5.6.1 Data Appended to Filter File Output Type 2 .....	33
5.6.2 Data Appended to Filter File Output Type 4 .....	35
5.6.3 Data Appended to Filter File Output Type 5 .....	36
5.6.4 Additional Filter File Output Type 6 .....	37
6.0 TRITON'S REMOTE COMMUNICATOR - REMOTE OFFLOAD TOOL .....	40

<b>6.1 Main Command Window .....</b>	<b>40</b>
<b>6.2 Remote Connect via TCP/IP .....</b>	<b>41</b>
6.2.1 Sierra Wireless RV50 Modem Configuration Settings.....	41
6.2.2 Telnet Screen .....	42
6.2.2.1 Get Directory .....	43
6.2.2.2 Offload File Data And Save To PC .....	43
6.2.2.3 Station Default Info .....	44
6.2.2.4 Start Unattended Logging.....	45
<b>6.3 Direct Connect via Serial Port .....</b>	<b>46</b>
6.3.1 Get Directory.....	47
6.3.2 Offload file(s).....	48
<b><u>7.0 UART OPERATING SYSTEM .....</u></b>	<b>48</b>
7.1 Start-up Message and Help Menu .....	48
<b><u>8.0 ADDENDUM: REMOTE CONTROL VIA CELLULAR MODEM .....</u></b>	<b>50</b>

## 1.0 Functionality

The autonomous node receiver is designed to be a self-sufficient, data-logging unit that sits above the water line with a hydrophone and temperature cable anchored to the bottom of marine and freshwater environments. The major components of the receiver system are shown in Figure 1-1.

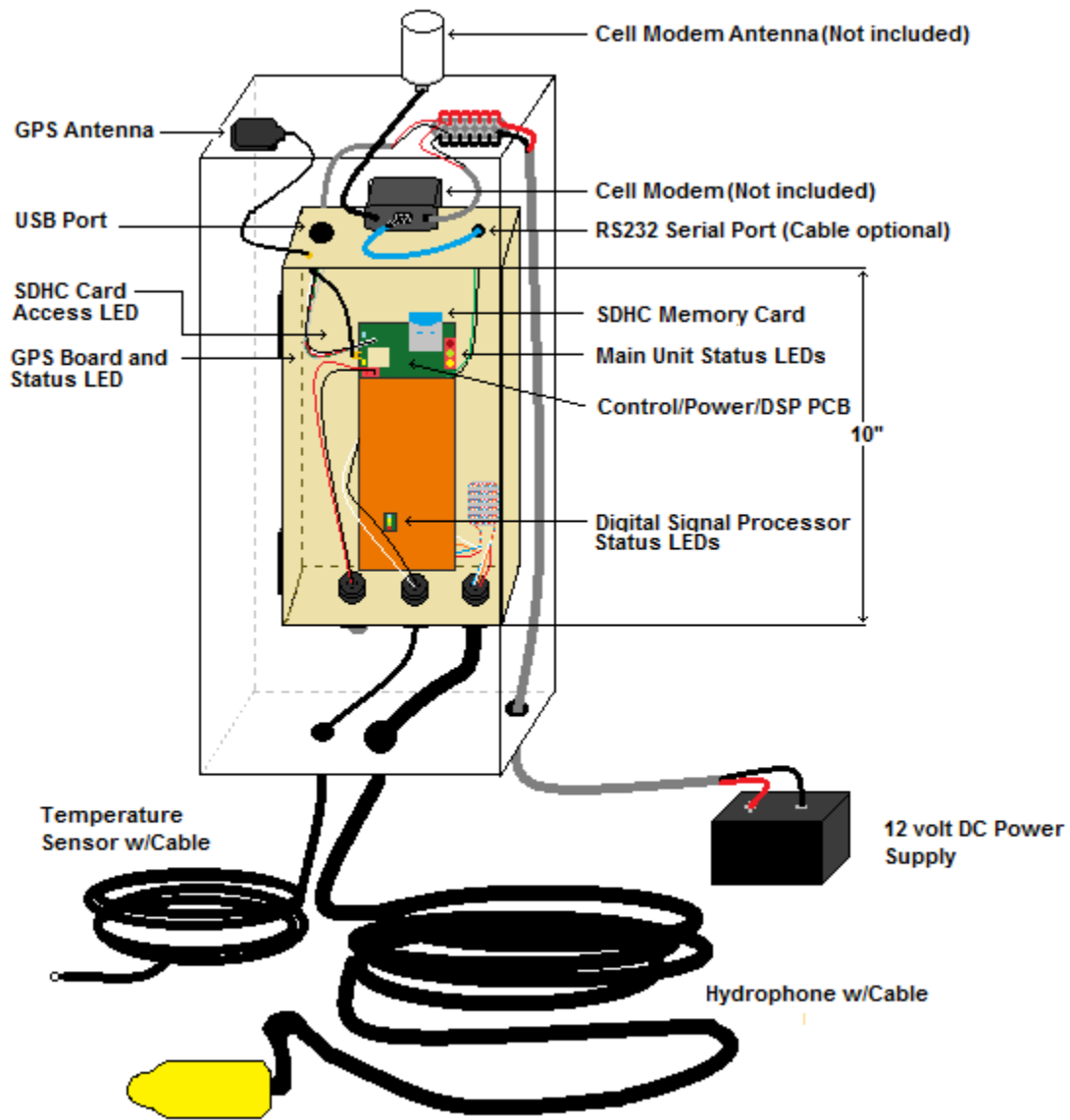

Figure 1-1

The hydrophone receives the high frequency mechanical vibrations sent through the water by the JSATS transmitter (in fish) and converts them to weak electrical voltages. These weak voltages are amplified and filtered by the preamplifier of the Control/Power board (to reduce noise) and then sent to the Digital Signal Processor (DSP) for processing.

The DSP converts the incoming filtered signals to digital numbers for use by the DSP in its detection and decoding algorithm. The detection algorithm looks for the existence of a tag and the decoding algorithm decides what specific tag code is present.

When a valid code is verified by the DSP it passes the detection information on for storage to the SDHC (High-capacity SD flash memory) card. The supervisory processor on the board manages the clocks, sensor measurements, data storage and the communication with the external USB and RS232 connections.

The receiver is equipped with sensors for temperature and GPS. The GPS is used to obtain accurate timing information for setting and syncing the multiple clocks. This is critical in providing accuracy for timestamping the signal arrival times. The data format has added columns for tilt and pressure which are optional sensors for the SR3001 acoustic receivers. The data recorded for these sensors will be displayed as “N/A”. The receiver queries temperature and voltage approximately every 15 seconds. If no tags are present this data will be saved and written to the flash card as dummy tag data approximately every 10 minutes.

The receiver is equipped with a USB port that can be used to see real-time data. This port can be accessed from the top edge of the housing by unscrewing the cover on the connector with the USB label. It uses a standard USB cable.

The receiver is equipped with an RS232 serial port that can be used to pull or push data stored on the SDHC memory card. This is handy for connecting to a cell modem, a serial RS232 to WIFI Converter or something similar for use in getting your data remotely. This can be done with or without added software provided by ATS. The com port settings are **115200, N, 8, 1** with no hardware handshaking. Additionally, there is a mobile model that using the same port to send GPS locations to a PC. These GPS locations are added to the tag detection information and stored on a PC file. To see the available commands

send a <CR> to trigger a prompt then enter a <?>. This port can be accessed from the top edge of the housing by unscrewing the cover on the connector with the RS232 label. It uses an optional serial cable for use with a cell modem or a serial cable for use with a PC provided on request. Make sure to specify the intended use.

The receiver is powered using a 12V power supply such as a deep cycle marine battery or solar panel.

#### Notes:

1. The power consumption of the receiver is ~70 milliamps during normal operation.
2. The recommended SDHC flash card is the SanDisk with a capacity of 32GB or smaller. The maximum data that can be stored to the card by the receiver is 32GB. The maximum file size is ~ 1GB. Additional files will be created till the 32 GB limit is reached.  
**Important Note: Make sure the flash card has been formatted using the Default format options. The file system usually will be FAT32. DO NOT format using the quick format option.**
3. A card reader (not supplied) is required for the SDHC card.

## **2.0 Start-up and LED Sequences**

With the housing open, place a SDHC flash card in the slot. The rest of the connections are attached to the outside of the box without needing to open the housing. Connect the power cable into the port connector found on the left bottom of the housing. The middle connector is for the temperature sensor and the connector on the right is for the hydrophone. See Figure 1-1. Observe the different status LEDs to understand what operation is taking place. There is a yellow GPS status LED positioned next to the GPS antenna connection that may or may not flash as the GPS module performs its different operations. This LED function will change depending on the GPS module used on the board. The blue SDHC LED will turn on whenever the flash card is being read from or written to. The main unit status LEDs are described in Table 2-1 below.

Sequence	Yellow LED	Green LED	Red LED	Event	Description
<b>Initialization Sequence</b>					
1	On	On	On	Power Up	
2	Off	On	On/Off	Reading Sensors, checking voltage ...	Flashing Red.
3	On or On/Off	Off	On or On/Off	Clock calibration and time sync.	If a GPS signal is present its default is to synchronize every 5 minutes.
<b>Windows Interface Routines</b>					
1	Off	On	Off	In the time keeping routine will not store tag detections. Do a power cycle to cancel.	Continuous solid Green
2	x	Off	On	Logging Routine Entered via user entered USB command. Do a power cycle to cancel.	Continuous solid Red. On while in the ATS Trident PC's logging routine. The receiver is sending tag detections to PC via the USB connection.
<b>Main Routine</b>					
x	Off	On	On	DSP Reset Scheduled	Red and Green on together
x	On/Off	Off	Off	GPS timing pulse is present	Flashing Yellow
x	On/Off	On/Off	On/Off	SDHC flash card not inserted in slot.	All three LEDs flash together

x	Off	On	On/Off	Reading sensors and voltage values	This happens every fifteen seconds. Will flash Red while Green is on if a sensor is disconnected or malfunctioning
x	Off	Off	On	Tag data decoded	Flashes for the first 2400 detections then quits.
x	On/Off	On/Off	On	Poor Signal. Indicates problem with the hydrophone or receiver front end.	Continuous solid red

Table 2-1



### 3.0 Data File Format

All tag detections are stored in “.csv” files that can be read directly by most text editors such as Microsoft’s “Excel” and “Notepad”. Files can be created hourly, daily or the default as one solitary file. On power up the receiver is set up to use only one file. It can be changed by receiving commands through its RS232 serial port. The commands “HON” and “DON” will trigger hourly file creation. The command “DAYON” will trigger daily file creation. The hourly and daily files are useful in remote file dumping since the files being dumped are smaller sizes. The filenames consist of the serial number and creation timestamps. The naming conventions are listed below:

1. SR20086\_yymmdd\_hhmm##.csv - Single name file format
2. SR20086Hyymmdd\_hhmm##.csv - Hourly file name format
3. SR20864Dyymmdd\_hhmm##.csv – Daily file name format

A snippet of an example data file is shown in Figure 3-1.

1												
2	Site Name: ATS		9 24									
3	File Name: SR20086D240228_000030.csv											
4	Serial Number: 20086											
5	ATS Sonic Receiver SR3017 Firmware v10.60											
6												
7	DSP v07.90											
8	File Format Version: 2.0											
9	File Start: 02/28/2024 00:00:30 -06z *FFFF+0227000030 5OFF											
10												
11	Internal	SiteName		DateTime	TagCode	Tilt	VBatt	Temp	Pressure	SigStr	Bit Period	TH
12												
13	000030 011B 00 x039 674 A	ATS	9 24	02/28/2024 00:00:02.837699	G722EB652	N/A	3.89	22.3	N/A	114	240	
14	000030 0241 00 x03A 674 A	ATS	9 24	02/28/2024 00:00:05.772472	G722EB652	N/A	3.89	22.3	N/A	129	240	
15	000030 0366 00 003B 674 A	ATS	9 24	02/28/2024 00:00:08.707963	G722EB652	N/A	3.89	22.3	N/A	135	239 28/31	
16	000030 048C 00 003C 674 A	ATS	9 24	02/28/2024 00:00:11.642636	G722EB652	N/A	3.89	22.3	N/A	143	239 30/31	
17	000030 05B1 00 003D 674 A	ATS	9 24	02/28/2024 00:00:14.578576	G722EB652	N/A	3.89	22.3	N/A	144	240	
18	000030 00FB 00 003E 674 A	ATS	9 24	02/28/2024 00:00:17.513937	G722EB652	N/A	3.89	22.3	N/A	111	239 30/31	
19	000030 0220 00 003F 674 A	ATS	9 24	02/28/2024 00:00:20.447956	G722EB652	N/A	3.89	22.3	N/A	114	240	
20	000030 0346 00 0040 674 A	ATS	9 24	02/28/2024 00:00:23.383053	G722EB652	N/A	3.89	22.3	N/A	130	239 30/31	
21	000030 046B 00 0041 674 A	ATS	9 24	02/28/2024 00:00:26.317622	G722EB652	N/A	3.89	22.3	N/A	134	239 30/31	
22	000030 0591 00 0042 674 A	ATS	9 24	02/28/2024 00:00:29.252399	G722EB652	N/A	3.89	22.3	N/A	146	239 30/31	
23	000044 00DA 00 x043 674 A	ATS	9 24	02/28/2024 00:00:32.187630	G722EB652	N/A	3.93	22.43	N/A	146	239 29/31	
24	000044 0200 00 x044 674 A	ATS	9 24	02/28/2024 00:00:35.122888	G722EB652	N/A	3.93	22.43	N/A	116	239 30/31	
25	000044 0325 00 0045 674 A	ATS	9 24	02/28/2024 00:00:38.057552	G722EB652	N/A	3.93	22.43	N/A	129	239 30/31	
26												
27	File End: 02/28/2024 00:00:38 *1A88+0228000044											
28												

Figure 3-1

### 3.1 Header Format

Table 3-1 gives a description of the information contained in lines 1-10 shown in Figure 3-1.

Line Contents	Description
Site/System Name	Descriptive name defined by the user and separated by two commas (e.g., “ATS, 09, 24”).
File Name	8 character site name which consists of “SR” followed by the serial number then a “_”, ”H”, or “D” depending on whether it is a single, hourly or daily type file. This is followed by date, time of file creation and partition number.(e.g., “SRser##_yymmdd_hhmm##_csv”)
Receiver Serial Number	A five-character serial number that designates the year of receiver production and three characters that designate sequential production number (e.g. “20086”)
Receiver Firmware Version	The name and version of the receiver supervisory firmware and the name.
DSP Firmware Version	The name and version of the DSP firmware.
File Format Version	Version number of the file format
File Start Date	Date and time signal acquisition began ( <i>mm/dd/yyyy hh:mm:ss hhz *nnnn+mmddhhmm</i> ) The 2-digit number preceding the letter ‘z’ is the offset from Coordinated Universal Time (UTC). For example, Figure 3-1 has ‘-05z’ which is UTC-5 hours or Central Daylight Savings Time. The zone is followed by ‘nnnn’. This a measure of the DSP clock’s time drift from the GPS sync pulse. The ‘+mmddhhmm’ is the timestamp taken when the drift measurement was done. Finally, there will either be a ‘5Off’ or ‘5M’ which indicates 5-minute sync ups are turned on or off.
File End Date	Date and time signal acquisition ended ( <i>mm/dd/yyyy hh:mm:ss *nnnn+mmddhhmm</i> ) Appears at the end of the data set. ‘nnnn’ is a measure of the DSP clock’s time drift from the GPS sync pulse. The ‘+mmddhhmm’ is the timestamp taken when the drift measurement was done.

Table 3-1

### 3.2 Data Format

Table 3-2 gives a description of the columns listed in line 11 shown in Figure 3-1.

Column Name	Description
Internal	Diagnostic and timing information. Data here will vary depending on the version.
SiteName	Descriptive name defined by the user and separated by two commas (e.g. "ATS , NC, 02").
DateTime	Date recorded as mm/dd/yyyy. Time of detection, defined as the time the signal arrives at the hydrophone (TOA) and shall be recorded with microsecond precision (hh:mm:ss.ssssss).
TagCode	9-digit tag code as decoded by receiver (e.g., "G720837eb") G72ffffff is used as a dummy tag for data recorded when no tag is present. Also, one line of text: "Old Clock" followed by a line of text: "New Clock" will appear in this field when the configuration window sends over a new time. Or it will be followed by "GPS Clock" when the GPS time was used to override the system clock.
Tilt	Tilt of the receiver (degrees). This typically will appear as "N/A" since this sensor is normally not included.
VBatt	Voltage of the receiver batteries (V.VV).
Temp	Temperature (C.CC°). If the temperature sensor is not attached or is malfunctioning it will read "99.99".
Pressure	Pressure outside of receiver (absolute PSI). This typically will appear as "N/A" since this sensor is normally not included.
SigStr	The logarithmic value for signal strength (in DB) "-99" signifies a signal strength value for an absent tag. A value <100 indicates a very weak signal. If no values appear above 100, check for a problem in the hydrophone cable or the receiver's front end.
BitPeriod	Optimal sample rate at 10 M samples per sec. To convert to frequency in kHz divide into 100,000.
Threshold	The logarithmic measurement of background noise that is used for the tag detection threshold. A value <100 indicates a very weak signal. If no values appear above 100, check for a problem in the hydrophone cable or the receiver's front end.

Table 3-2

## **4.0 H2O Trident Series USB Interface And Filter Software**

The H2O *Trident* Receiver Mobile SR3001 and SR3017 Series interface and filter software can be downloaded from our website. The software is compatible with Windows 10 and Windows 11 operating systems. After downloading the software to your PC, click on the setup executable and follow the instructions. It contains tools for real time logging, GPS location stamping while using the Mobile firmware and postprocessing filter and combine tools.

Driver Installations: The *Trident* software will walk you through installing the USB driver and GPS Log Function (Python) software on its first boot up. If it is not done here the software will need to be installed as a separate step. The driver installation can be initiated by going into **Setup** on the toolbar of the main command window and selecting **Install Driver and/or Install GPS Log Function**.

### **4.1 Main Command Window**

The first screen that appears after the software is started is the Main Command window, shown in Figures 4-1 through 4-2.

The USB Communication mode allows for real-time data viewing while a computer is attached to the USB port. The USB connection takes a few seconds to initialize before indicating it is ready. When the serial number appears at the bottom of the screen and the **Ready** message appears as in figure 4-2, click **OK**. The serial number of the receiver can be found on the placard affixed to copper shielding easily viewed through the clear window of the receiver's housing.

The USB connection allows you to update the receiver's configuration - **Edit Configuration** and view the tags as they are being decoded - **View Logging Data**. If the USB connection should hang up, un-plug and re-plug the connection to reestablish communication.

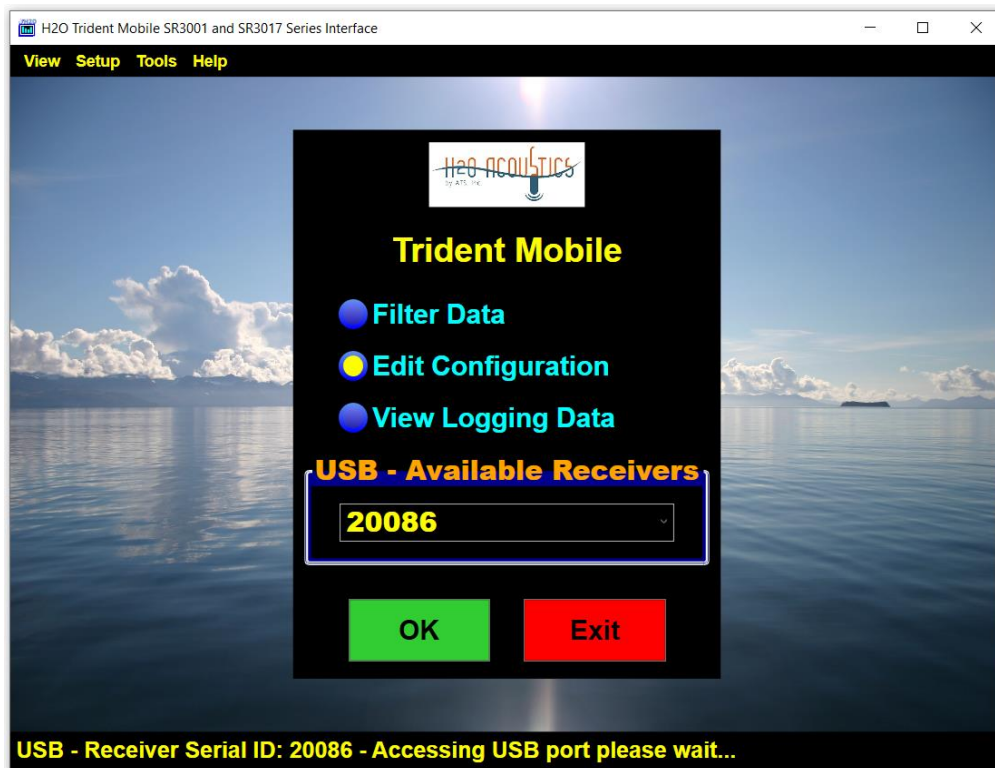

Figure 4-1

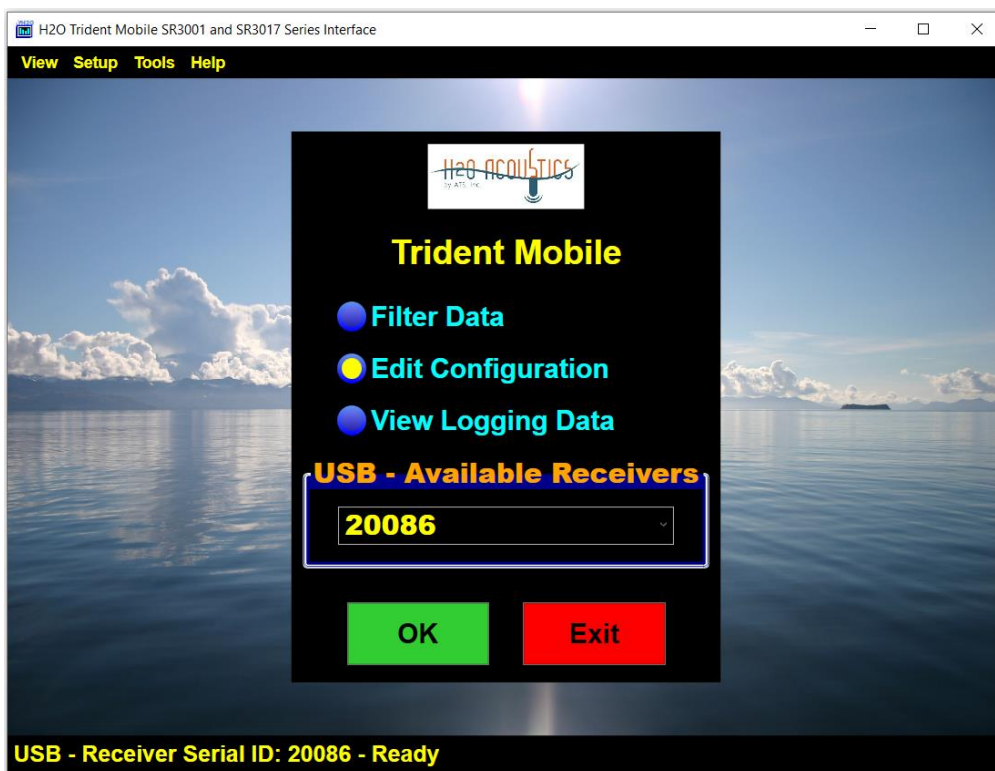

Figure 4-2

## 4.2 Edit Configuration

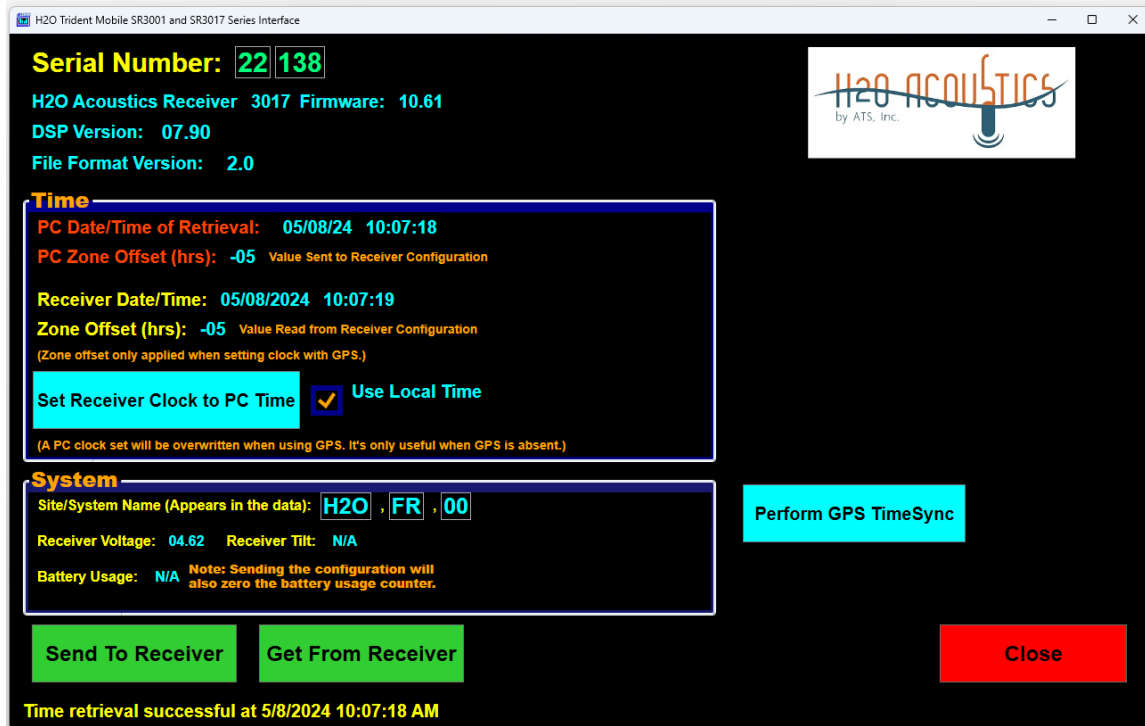

Figure 4-3

This function accessed by the USB connection allows access to the *Trident* receiver's configuration. Upon entering this screen, the receiver will also enter a special timekeeping mode so that it can continuously update the time portion of the display in realtime. While in this mode the green status LED will be lit continuously.

To update the time and date on the receiver so it matches the PC's, click on the blue button **Set Receiver Clock to PC Clock**, and the PC time and date will be sent to the *Trident* receiver, synchronizing the two clocks.

The offset from Coordinated Universal Time (UTC) will also be sent and stored on the receiver but to set that click on the green button **Send to Receiver**. If the Local Time check box is not clicked UTC time will be used.

When the *Trident* receiver updates its clock it will send to the SDHC card two lines of data. The first represents the time of the update using the old time, and the second the time of the update using the newly corrected time. The **Site Name** for the SR3017 is fixed. It will be "SR" followed by the receiver serial number. The **Site/System Name** is customizable and will be sent over as it appears on the screen but is done as a separate step by clicking on the green button **Send to Receiver** located at the bottom of the

screen. When finished, make sure to click on the red **Close** button so the receiver will get the command to exit the timekeeping mode. Otherwise, cycling the power on the receiver will accomplish the same thing.

The time setting here will be overwritten by GPS time on boot up or when the hour rolls over if it is able to get the information from the satellite constellation. If you will be running these units where you will have access to GPS then you only need to do this configuration step once. This step will save the time zone stored on your PC which will allow your GPS sync'd timestamps to appear as local time. The GPS sync'd time will never be in daylight savings time. Using the GPS to set the clock provides improved accurate time syncing across different SR3017 units.

Clicking on the blue **Perform GPS TimeSync** will turn on the GPS unit and trigger that functionality to set the time. Note: Make sure the external GPS antenna is plugged in and has a clear view of the sky.

### 4.3 View Real Time Logging

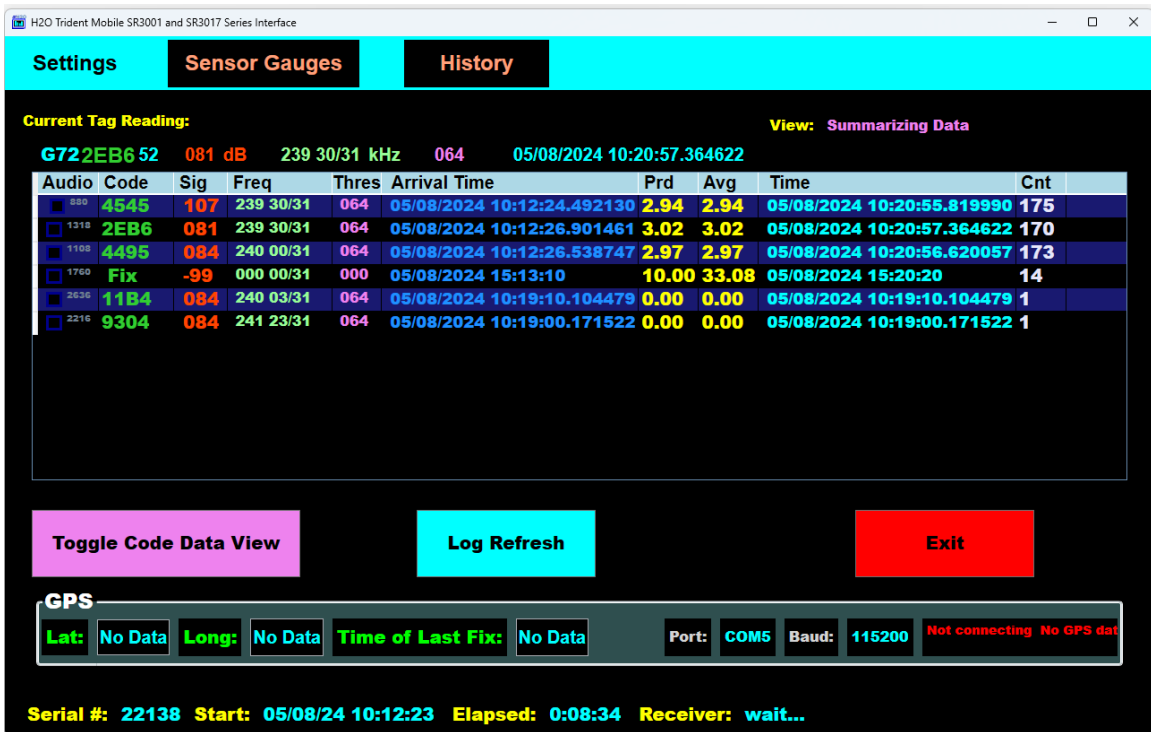

Figure 4-4

You may view real time datalogging of tag data using the USB connection by selecting the **View Realtime Logging** button. This displays the data as it is being captured by the *Trident* Receiver.

If the SDHC card is present in the SD card slot of the receiver, data will appear in blocks of fifteen seconds of accumulated data, with data appearing every 15 seconds on the screen.

If the SD card slot is empty, the data will be displayed immediately as it is detected.

Over time this data could develop a time lag depending on the amount of data being printed to the screen and the speed of the PC.

The **View Realtime Logging** function has two display options to facilitate viewing the incoming data. Clicking the Toggle Code Data View will change the display from **Summarizing Data** to **Single Detections** as shown in Figure 4-5.

The **Summarizing Data** option will display one data line per tag. The screen is refreshed for each new data point. The **Single Detection** option displays a new line for each detection.

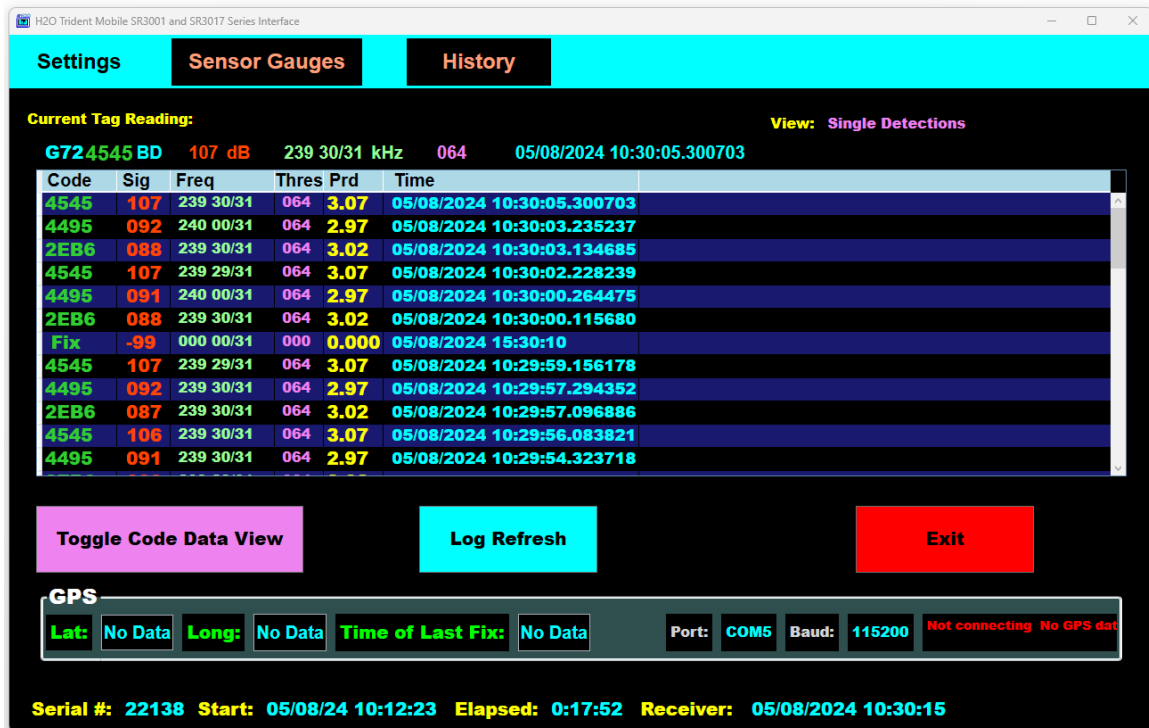

Figure 4-5

This screen also shows in the farthest left column a speaker icon followed by a column of check boxes. If a tag code is checked it will play a tone at a frequency specific to that tag code. The volume will be tied to it's last signal strength value. If tags are being detected



close together you may only hear one of the tags. Ideally keep the number of boxes checked to a small number.

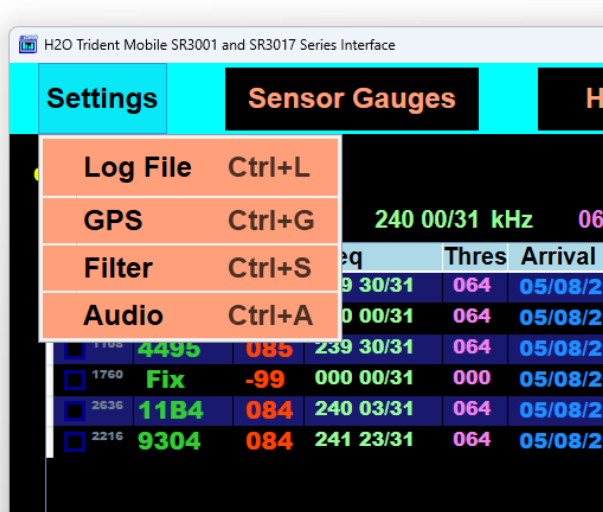

Figure 4-6

Options can be selected from the **Settings** drop-down menu at the top of the screen, as shown Figure 4-6. It can be selected to filter detections having periods too large or too small to be valid. This option is shown below in Figure 4-7.

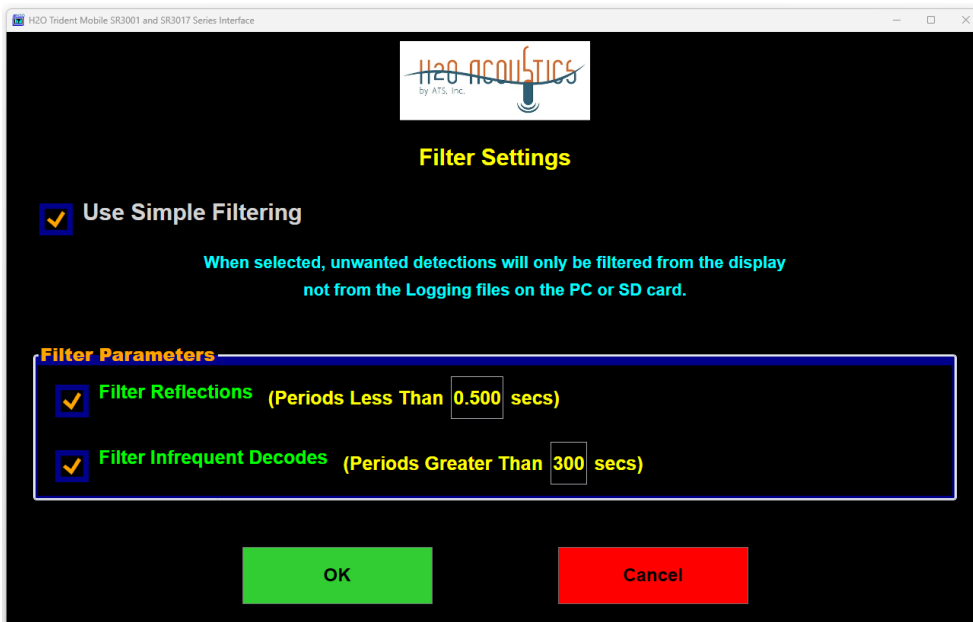

Figure 4-7

The frequency range played, for the audio tones, if enabled, can be adjusted to accommodate people who have limited ability to pick up certain frequency ranges. Figure 4-8.

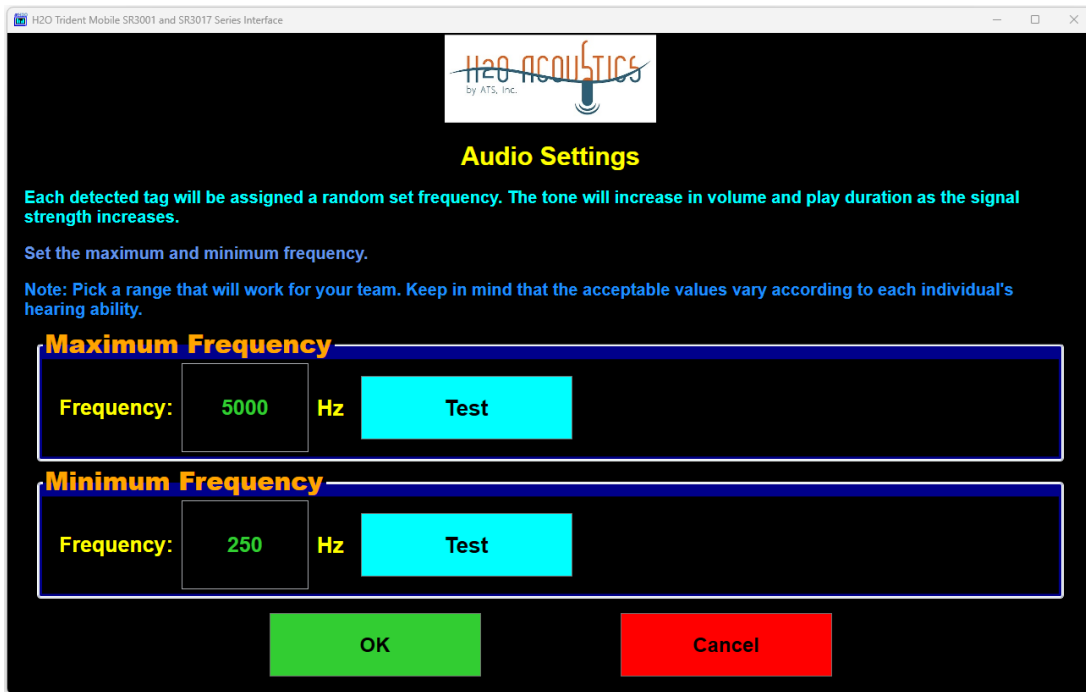

Figure 4-8

The Sensor Gauges shown in figure 4-9, display the values being picked up by the receiver sensors. The figure shown is for an SR3017 that has no tilt and has the temperature sensor cable disconnected.

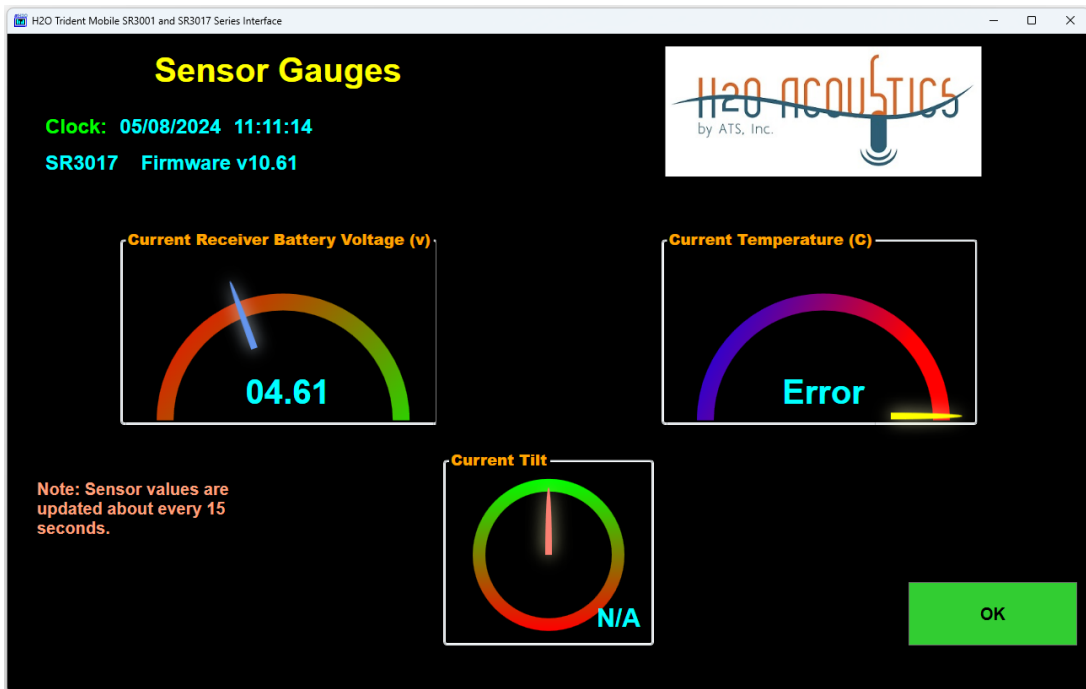

Figure 4-9

## 4.4 GPS Data Tagging for Mobile Tracking

When mobile tracking and logging data to the PC there is an option to read in serial data from a GPS unit or a special SR3017 “Mobile” version receiver. The RS232 serial data out must be streaming the NMEA \$GPRMC sentences at a baudrates of 4800, 9600, or 115200. The special SR3017 “Mobile” version receiver uses 115200 and streams the GPS data out its port with the RS232 label. On request an optional PC serial cable is provided for the receiver. Make sure to enter the baudrate and com port used under the “Settings” Tool bar option as shown in Figure 4-10. If you are using a GPS receiver instead of the special SR3017 “Mobile” version receiver make sure it is using the following settings: Data – 8 bit, Parity – none, Stop bits – 1 and no flow control.

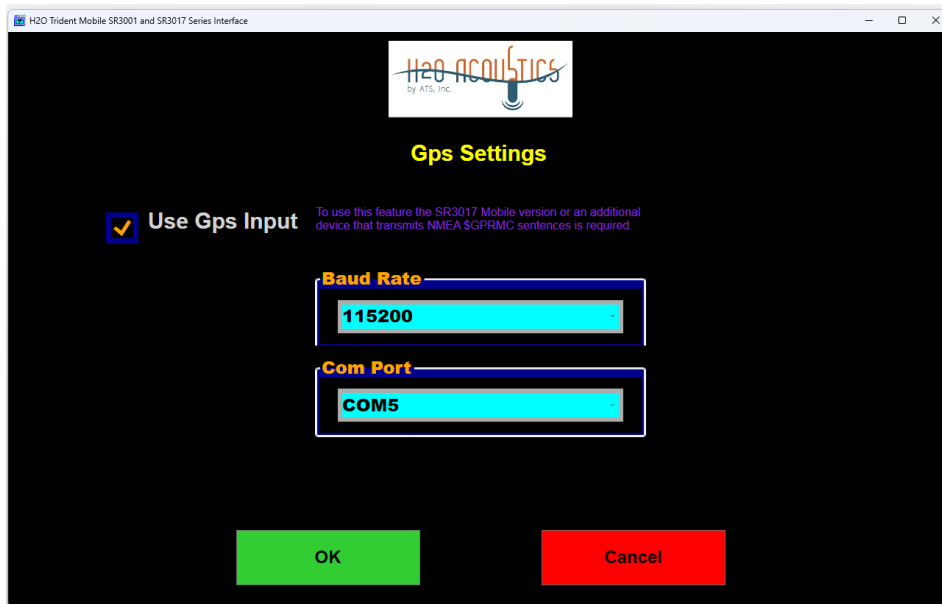

Figure 4-10

When “Mobile Tracking”, both the options for using a log file and using GPS input has to be selected in the settings. See Figures 4-6, 4-10 and 4-11. You may have to exit the software and reenter after selecting the options for them to take effect.

Note: If you want to log GPS points on the SDHC card instead, a special float version of firmware can be requested that stores a GPS location every minute. Make sure to set up the external GPS antenna so it has a clear view of the sky.

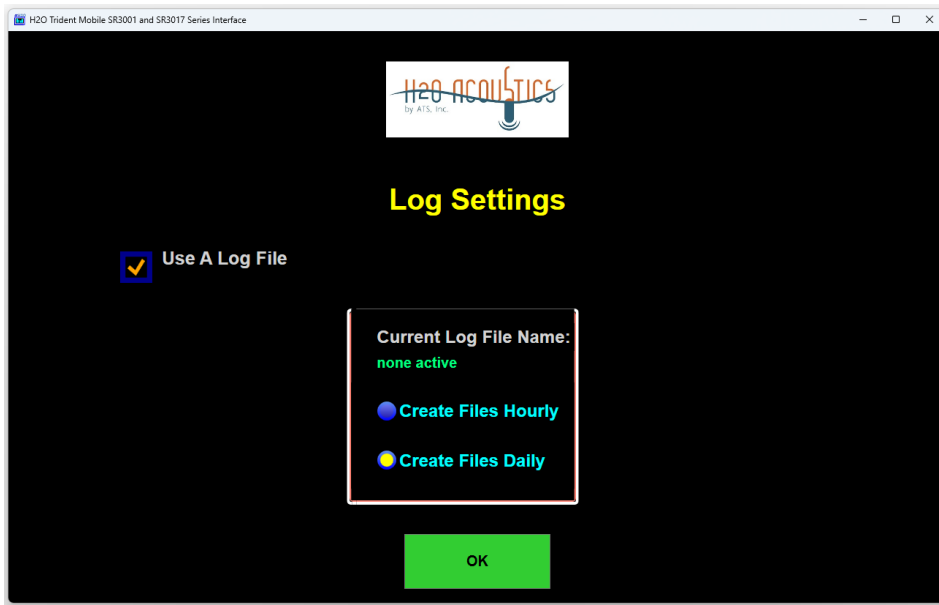

Figure 4-11

When the logging with GPS option is selected the logging screen will look something like Figure 4-12.

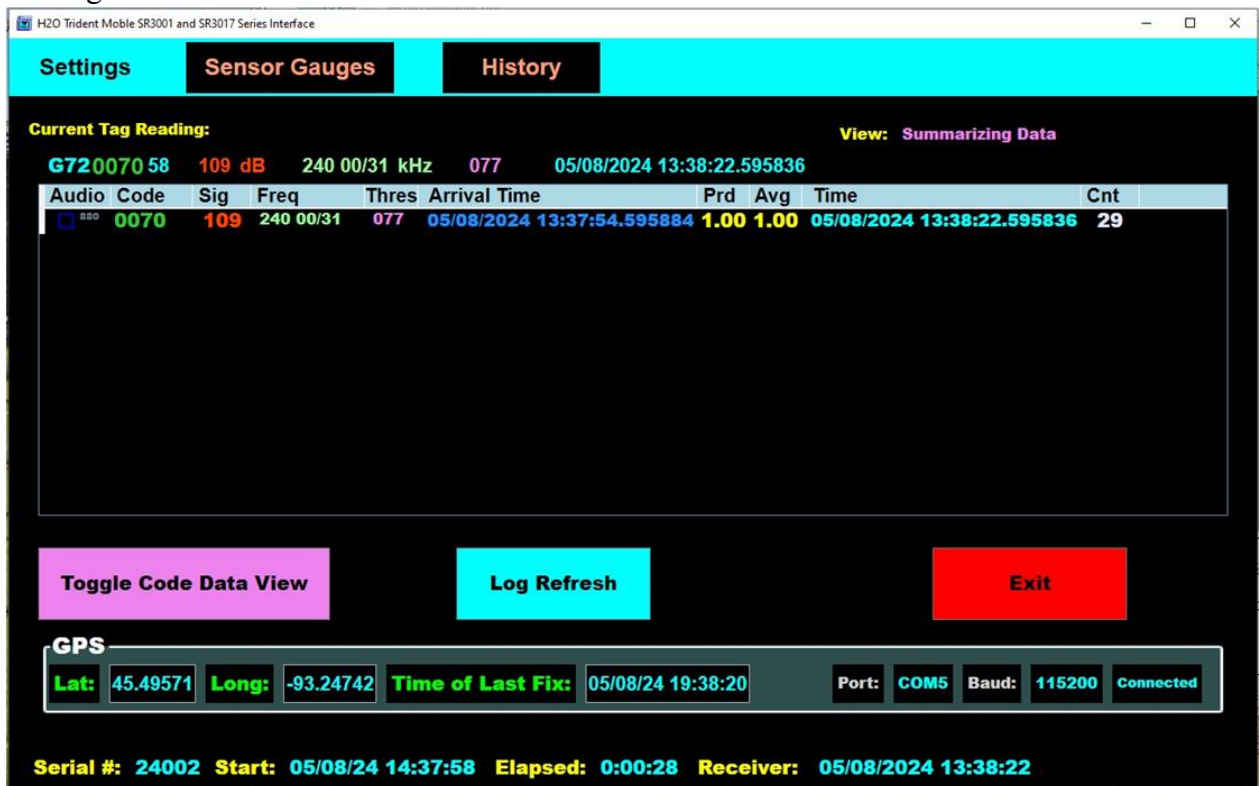

Figure 4-12

At the conclusion of the logging session the data will be found on the PC in the directory: “> Local Disk (C:) >Advanced Telemetry Systems, Inc > H2O Trident Receiver > Log”. A snippet of an example Log file containing GPS data is shown in Figure 4-13.

Internal	SiteName	Date	Time	TagCode	Tilt	VBatt	Temp	Pressure	SigStr	Bit Period	Threshold	Latitude	Longitude	Time GPS Retrieved
SR24002_240508_Gps.csv	PC	Log	File	05/08/2024	G7200705	N/A	12.02	22.06	N/A	109 240 2/31	076	No Data	No Data	No Data
SR24002_240508_Gps.csv	PC	Log	File	05/08/2024	G7200705	N/A	12.02	22.06	N/A	109 240	078	No Data	No Data	No Data
SR24002_240508_Gps.csv	PC	Log	File	05/08/2024	G7200705	N/A	12.02	22.06	N/A	108 240 1/31	077	No Data	No Data	No Data
SR24002_240508_Gps.csv	PC	Log	File	05/08/2024	G7200705	N/A	12.02	22.06	N/A	108 240	076	No Data	No Data	No Data
SR24002_240508_Gps.csv	PC	Log	File	05/08/2024	G7200705	N/A	12.02	22.06	N/A	108 240 2/31	076	-93.2474	45.49571	05/08/24 19:38:10
SR24002_240508_Gps.csv	PC	Log	File	05/08/2024	G7200705	N/A	12.02	22.06	N/A	109 240 1/31	077	-93.2474	45.49571	05/08/24 19:38:10
SR24002_240508_Gps.csv	PC	Log	File	05/08/2024	G7200705	N/A	12.02	22.06	N/A	108 240	078	-93.2474	45.49571	05/08/24 19:38:10
SR24002_240508_Gps.csv	PC	Log	File	05/08/2024	G7200705	N/A	12.02	22.06	N/A	109 240	080	-93.2474	45.49571	05/08/24 19:38:10
SR24002_240508_Gps.csv	PC	Log	File	05/08/2024	G7200705	N/A	12.02	22.06	N/A	107 240	078	-93.2474	45.49571	05/08/24 19:38:10
SR24002_240508_Gps.csv	PC	Log	File	05/08/2024	G7200705	N/A	12.02	22.06	N/A	107 240 2/31	079	-93.2474	45.49571	05/08/24 19:38:10
SR24002_240508_Gps.csv	PC	Log	File	05/08/2024	G7200705	N/A	12.02	22.06	N/A	109 240	079	-93.2474	45.49571	05/08/24 19:38:10
SR24002_240508_Gps.csv	PC	Log	File	05/08/2024	G7200705	N/A	12.02	22.06	N/A	109 240	079	-93.2474	45.49571	05/08/24 19:38:10
SR24002_240508_Gps.csv	PC	Log	File	05/08/2024	G7200705	N/A	12.02	22.06	N/A	107 240	078	-93.2474	45.49571	05/08/24 19:38:10
SR24002_240508_Gps.csv	PC	Log	File	05/08/2024	G7200705	N/A	12.02	22.06	N/A	109 240	080	-93.2474	45.49571	05/08/24 19:38:10
SR24002_240508_Gps.csv	PC	Log	File	05/08/2024	G7200705	N/A	12.02	22.06	N/A	108 240 2/31	077	-93.2474	45.49571	05/08/24 19:38:10
SR24002_240508_Gps.csv	PC	Log	File	05/08/2024	G7200705	N/A	12.02	22.06	N/A	109 240	079	-93.2474	45.49571	05/08/24 19:38:10
SR24002_240508_Gps.csv	PC	Log	File	05/08/2024	G7200705	N/A	12.02	22.06	N/A	107 240	077	-93.2474	45.49571	05/08/24 19:38:10
SR24002_240508_Gps.csv	PC	Log	File	05/08/2024	G7200705	N/A	12.02	22.06	N/A	108 239 30/31	078	-93.2474	45.49571	05/08/24 19:38:10

Figure 4-13

## 4.5 Filter Data

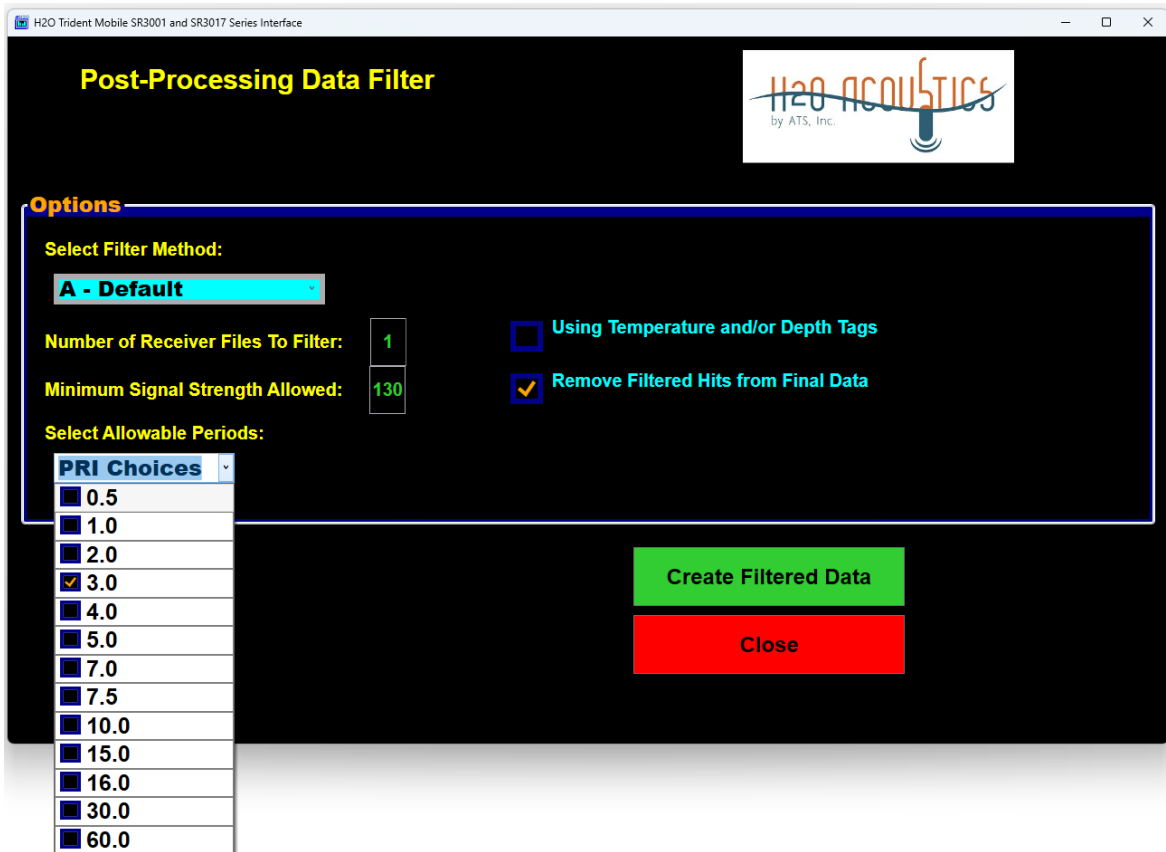

Figure 4-14

This option does not make use of an active USB connection. It takes as input one or more of the *Trident* Receiver files residing on your computer that have been copied over from the SDHC card(s). It post-processes the data by filtering out invalid data, splitting the files into smaller chunks and summarizing run data.

## 4.5.1 Standard JSAT's Coded Tags

For standard JSAT's coded tags, there are two filtering methods to choose from. They give slightly different results. Method "A-Default" and method "B-Minimum Mode".

Method "A" (Default - SVP) looks for tags with consecutive repeating periods that are within a certain range of the selected nominal period(s). These periods need to stay within a narrow range of each other.

Method B developed by Pacific Northwest National Laboratory (PNNL) uses a moving window. The window size is about 12 times the estimated pulse rate interval. In this window the tag period used is the minimum mode value close to the nominal. Both of these routines can take a while to process all the data. It does allow a number of files to be processed at a time. As it processes, the status will be displayed.

Before starting the routine, make sure to check the boxes next to the periods of the sonic transmitters you used. Figure 4-14 shows a period of 3 seconds checked.

## 4.5.2 Temperature and Depth Tags

H2O Acoustics manufactures in addition to standard JSAT's coded tags, a variety of tags that transmit the JSATs ID along with the tag's current temperature and/or depth. This data can be retrieved and deciphered by clicking on the check box located at the bottom of the screen shown in Figure 4-14. This option is only available using Filter Method "A-Default".

Processing the temperature and depth tag data will require additional input into the filter program.

### 4.5.2.1 Sensor Tag Code List

A simple ".csv" file is needed for input containing a list of the temperature and/or depth tag codes that were deployed. Below is what the contents of a possible file would look like...

```
G724995A7  
G724D5B49  
G72453398  
G72452BC7
```

G724A9193  
G722A9375  
G724BA92B  
G724A2D02

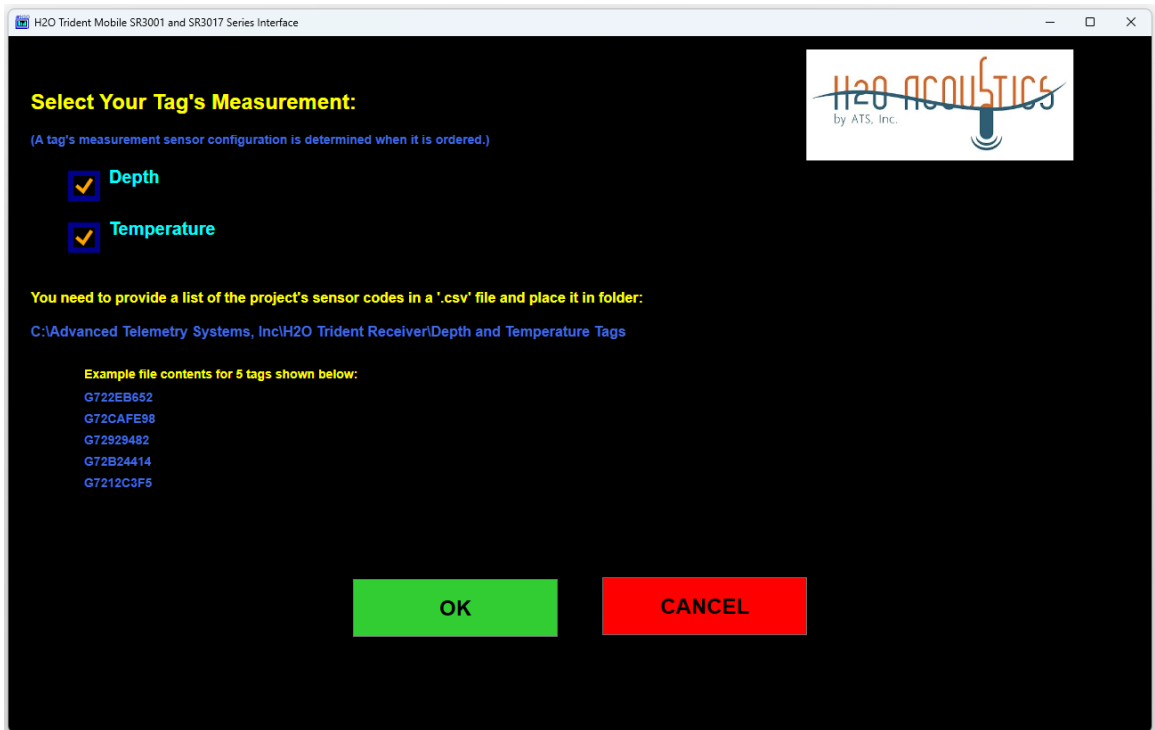

Figure 4-15

## 4.5.2.2 Barometric Pressure

Shown in Figure 4-15 is the entry screen used for Depth tags. The Depth tags can be purchased as depth only or as a combination temperature depth tag. Depth measurement is really a measurement of pressure. To calculate depth the local barometric pressure needs to be considered. This pressure frequently changes, but the filter can only use one value for its depth calculation. Pick a midrange value that is representative of the site's average barometric pressure during the time the data was collected.

The value entered can be designated in units of atmospheres (atm), mercurial inches (inHg), kilopascals (kPa), millibars (mBar), mercurial millimeters (mmHg), or pounds per square inch (psi). Ensure that the correct type of units is selected, or else incorrect results will be calculated.

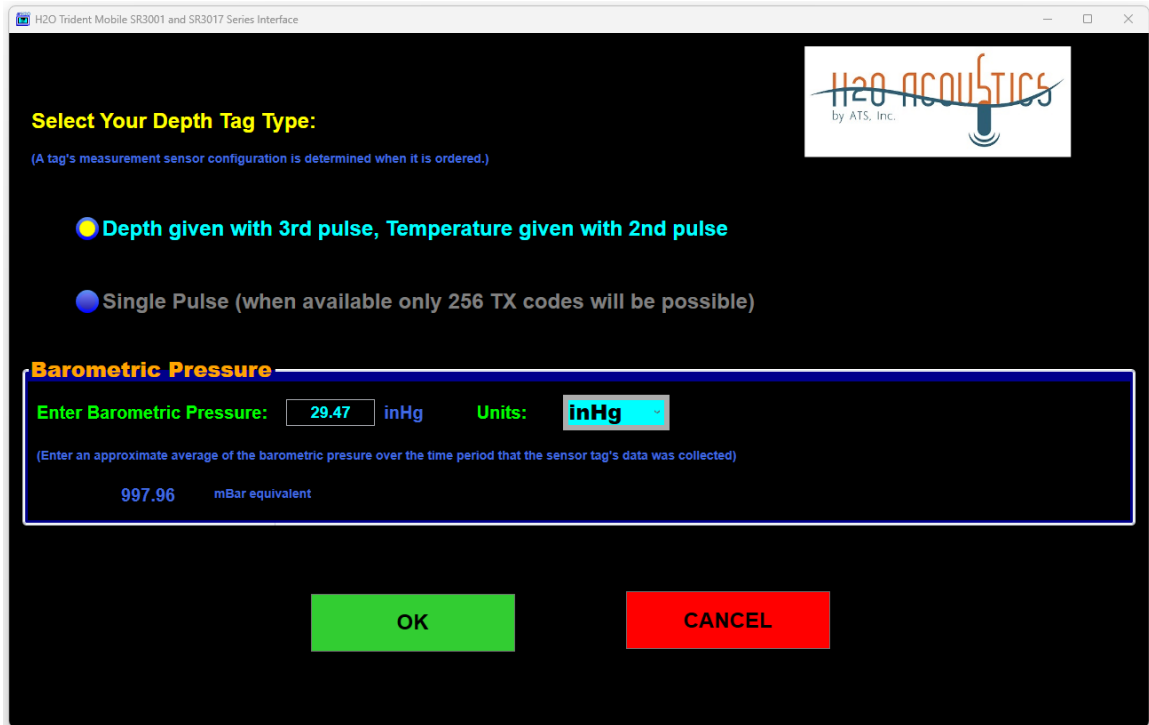

Figure 4-16

### 4.5.2.3 Temperature Only Tags

Shown in Figure 4-17 is the entry screen used for Temperature only tags. The default temperature only tag is the “Model SS400 (SB) Alternating Code ID/Temperature Acoustic Tag”.



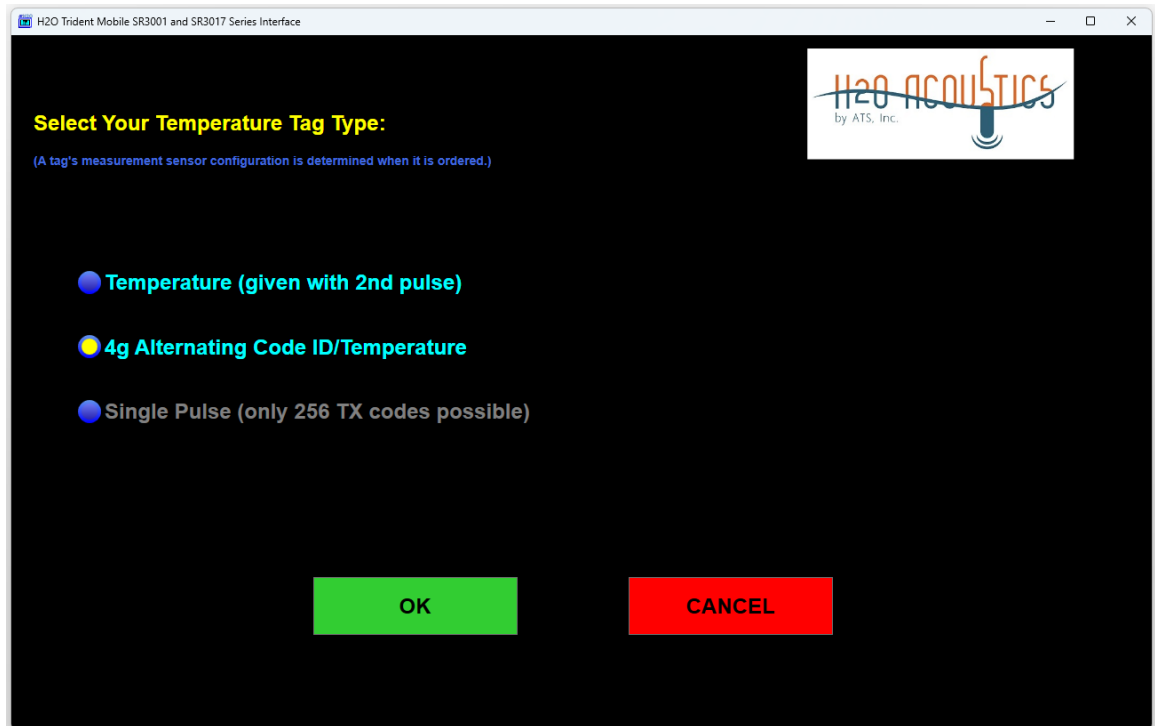

Figure 4-17

This is shown as selected in the figure. It works by transmitting its tag ID code every other ping. For example, a tag using a 3 sec PRI will ping every 3 seconds, but its ID code will only appear once every 6 seconds. The alternating ping will be a code that contains temperature information in Celsius (also only seen once every 6 seconds).

The Temperature Code is a 16-bit hexadecimal number with an 8-bit CRC suffix.

- . Bits 15 – 6 will be the same as the ID code.
- . Bit 5 will be the opposite of the ID code's bit 5. This guarantees that the alternate temperature code will always be different than the ID code.
- . Bits 0 - 4 (5 bits total) will be the binary value of the temperature in Celsius (0C to 31C)
- . The pulse code that appears just before the version (on power-up) and after the version will be the temperature code.
- . The temperature value is measured every 8 pulses during normal operation (thus there will be a minimum of four temperature pulses for each temperature measured)

## **5.0 Filter Data File Format**

After all the parameters have been selected a dialog box will prompt you for the file you want to process.

When the filter option from the **File Data** dialog is finished running there will be a number of new files created. They will consist of 5 different types.

Example input file name:

SR24102\_241027\_110701.csv

One example each of the 5 types of output files:

- Type 1) SR24102\_241027\_110701\_Log1\_1027\_1107\_2.csv
- Type 2) SR24102\_241027\_110701\_DData\_Log1\_1027\_1107\_2.csv or  
SR24102\_241027\_110701\_MData\_Log1\_1027\_1107\_2.csv
- Type 3) SR24102\_241027\_110701\_RejectedTags\_Log1\_1027\_1107\_2.csv
- Type 4) SR24102\_241027\_110701\_Cleaned\_Log1\_1027\_1107\_2.csv
- Type 5) SR24102\_241027\_110701\_summary\_Log1\_1027\_1107\_2.csv

For Sensor Tags Only

- Type 6) SR24102\_241027\_110701\_SensorTagData\_Log1\_1027\_1107\_2.csv

### **5.1 Filter File Output Type 1**

Example Type 1 output file names:

SR24102\_241027\_110701\_Log1\_1.csv  
SR24102\_241027\_110701\_Log1\_1027\_1107\_2.csv  
SR24102\_241027\_110701\_Log2\_1027\_1110\_1.csv  
SR24102\_241027\_110701\_Log2\_1027\_1110\_2.csv

·  
·  
·

The input file can contain multiple logging sessions which are defined to be a power cycle or the insert and removal of a SDHC card. The input file can be larger than some programs like Excel can handle. Type 1 files are partitioned copies of the input file. These partitions isolate data into files according to the log session and they keep the files smaller than 50,000 lines of data.

## 5.2 Filter File Output Type 2

Example Type 2 output file names when the “A – Default” selection in the File Data dialog was selected:

```
SR24102_241027_110701_DDData_Log1_1027_1107_1.csv
SR24102_241027_110701_DDData_Log1_1027_1107_2.csv
SR24102_241027_110701_DDData_Log2_1027_1110_1.csv
SR24102_241027_110701_DDData_Log2_1027_1110_2.csv
```

.

.

Example Type 2 output file names when the “B – Minimum Mode” selection in the File Data dialog was selected:

```
SR24102_241027_110701_MData_Log1_1027_1107_1.csv
SR24102_241027_110701_MData_Log1_1027_1107_2.csv
SR24102_241027_110701_MData_Log2_1027_1110_1.csv
SR24102_241027_110701_MData_Log2_1027_1110_2.csv
```

.

.

.

Type 2 files have all the information of the Type 1 files with additional information added on. This file will not include rejected data if the filter was run with the **Remove Filtered Hits from Final Data** checkbox checked from the File Data dialog.

1	Detection Date/Time	TagCode	RecSerialNum	FirmwareVer	DspVer	FileFormatVer	LogStartDate	LogEndDate	FileName
2	10/30/2017 16:54:11.612030	G7222226F	17102	6.06	5.1	2	10/27/2017 11:14	10/27/2017 11:12:13 *0000+1027110955	165400 0001 00 0007 F7 60
3	10/30/2017 16:54:15.485950	G72AAEE5F	17102	6.06	5.1	2	10/27/2017 11:14	10/27/2017 11:12:13 *0000+1027110955	165415 003C 00 1007 F7 60
4	10/30/2017 16:54:32.748180	G7222226F	17102	6.06	5.1	2	10/27/2017 11:14	10/27/2017 11:12:13 *0000+1027110955	165430 003C 00 1007 F7 60
5	10/30/2017 16:54:38.032094	G7222226F	17102	6.06	5.1	2	10/27/2017 11:14	10/27/2017 11:12:13 *0000+1027110955	165430 003C 00 0007 F7 60
6	10/30/2017 16:54:43.315905	G7222226F	17102	6.06	5.1	2	10/27/2017 11:14	10/27/2017 11:12:13 *0000+1027110955	165430 0001 00 0008 08 60
7	10/30/2017 16:54:47.509161	G72AB68CA	17102	6.06	5.1	2	10/27/2017 11:14	10/27/2017 11:12:13 *0000+1027110955	165445 003C 00 1008 08 60
8	10/30/2017 16:54:57.655963	G72AB68CA	17102	6.06	5.1	2	10/27/2017 11:14	10/27/2017 11:12:13 *0000+1027110955	165445 003C 00 0008 08 60
9	10/30/2017 16:56:13.108561	G7222226F	17102	6.06	5.1	2	10/27/2017 11:14	10/27/2017 11:12:13 *0000+1027110955	165600 003C 00 1008 08 60
10	10/30/2017 16:57:27.026086	G7222226F	17102	6.06	5.1	2	10/27/2017 11:14	10/27/2017 11:12:13 *0000+1027110955	165715 003C 00 1008 18 60

Figure 5-1

Column Name	Description
Detection Date/Time	Date recorded as mm/dd/yyyy. Time of detection, defined as the time the signal arrives at the hydrophone (TOA) and shall be recorded with microsecond precision (hh:mm:ss.ssssss)
TagCode	9-digit tag code as decoded by receiver (e.g., “G7280070C”) G72ffffff is used as a dummy tag for data recorded when no tag is present.

RecSerialNum	A five-character serial number that designates the year of receiver production and three characters that designate sequential production number (e.g. “18035”)
FirmwareVer	The version of the receiver supervisory firmware.
DspVer	The version of the DSP firmware.
FileFormatVer	Version number of the file format.
LogStartDate	Date and time signal acquisition began for this logging session (mm/dd/yyyy hh:mm:ss)
LogEndDate	Date and time signal acquisition finished for this logging session (mm/dd/yyyy hh:mm:ss *#####+mmddhhmmss)
FileName	Diagnostic and timing information. Data here will vary depending on the version.

Table 5-1

	SitePt1	SitePt2	SitePt3	Tilt	VBatt	Temp	Pressure	SigStr	BitPrd	Threshold	ImportTime	TimeSince	Multipath	FilterType	Filtered	NominalPRI	
2	ATS	9	14	24	3.35	2.36	13.8	203	240	153	1/3/2018 11:41	5.283731	No	SVP	No	5	
3	ATS	9	14	24	3.36	2.36	13.8	196	240	154	1/3/2018 11:41	96.08753	No	SVP	Yes	5	
4	ATS	9	14	24	3.36	2.36	13.8	200	240	153	1/3/2018 11:41	21.13615	No	SVP	No	5	
5	ATS	9	14	24	3.36	2.36	13.8	205	240	152	1/3/2018 11:41	5.283914	No	SVP	No	5	
6	ATS	9	14	24	3.36	2.36	13.8	217	240	151	1/3/2018 11:41	5.283811	No	SVP	No	5	
7	ATS	9	14	24	3.36	2.36	13.8	207	240	154	1/3/2018 11:41	126.7838	No	SVP	Yes	0	
8	ATS	9	14	24	3.36	2.36	13.8	206	240	154	1/3/2018 11:41	10.1468	No	SVP	Yes	0	
9	ATS	9	14	24	3.35	2.36	13.8	180	240	2/31	154	1/3/2018 11:41	89.79266	No	SVP	No	5
10	ATS	9	14	24	3.35	2.36	13.8	200	240	152	1/3/2018 11:41	73.91752	No	SVP	No	5	

Figure 5-2

SitePt1	Site name part 1. Descriptive name defined by the user.
SitePt2	Site name part 2. Descriptive name defined by the user.
SitePt3	Site name part 3. Descriptive name defined by the user.
Tilt	Tilt of the receiver (degrees). This typically will appear as “N/A” since this sensor is normally not included.
VBatt	Voltage of the receiver batteries (V.VV).

Temp	Temperature (C.CC°). If the temperature sensor is not attached or is malfunctioning it will read “99.99”.
Pressure	Pressure outside of receiver (absolute PSI). This typically will appear as “N/A” since this sensor is normally not included.
SigStr	The logarithmic value for signal strength (in DB) “-99” signifies a signal strength value for an absent tag.
BitPrd	Optimal sample rate at 10 M samples per sec (related to tag frequency)
Threshold	The logarithmic measurement of background noise used for tag detection threshold.
ImportTime	Date and time this file was created (mm/dd/yyyy hh:mm:ss)
TimeSince LastDet	Elapsed time in seconds since the last detection of this code.
Multipath	Yes/No value indicating if the detection was from a reflected signal.
FilterType	SVP (Default)/ MinMode value indicating the choice of filtering algorithm used on this data.
Filtered	Yes/No value indicating if this data has been rejected.
NominalPRI	The assumed programmed value for the tag’s pulse rate interval.

Table 5-2

1	DetNum	EventNum	EstPRI	AvePRI	ReleaseDate	Notes
2	8	1	5.283668	7.519982		
3	**	1	5.069434	233.6836		Removed on Final Filter Pass
4	9	1	5.283668	7.519982		
5	10	1	5.28375	7.519982		
6	11	1	5.283765	7.519982		
7	2*	0	0	8.85854		Invalid PRI
8	3*	0	0	8.85854		Invalid PRI
9	12	1	5.283765	7.519982		
10	13	1	5.283765	7.519982		

Figure 5-3

DetNum	The current detection number for this accepted code, or if followed by an asterisk, the count of previously rejected hits for this code.
EventNum	This count increases if there is a reacquisition of this code after an acquisition loss. For the SVP method this loss needs to be $\geq 30$ minutes. For MinMode an acquisition loss happens if there are less than 4 hits contained within an acceptance window of 12 nominal PRIs.
EstPRI	The estimated PRI value.
AvePRI	The average PRI value.
FalseCode	The original code before being corrected for being a false code.
ReleasedDate	
Notes	

Table 5-3

### 5.3 Filter File Output Type 3

Type 3 files have the detection data for rejected codes.

Example Type 3 for the Default SVP filter output file names:

```
SR24102_241027_110701_RejectedTags_Log1_1027_1107_1.csv
SR24102_241027_110701_RejectedTags_Log1_1027_1107_2.csv
SR24102_241027_110701_RejectedTags_Log2_1027_1110_1.csv
SR24102_241027_110701_RejectedTags_Log2_1027_1110_2.csv
```

·  
·  
·

## 5.4 Filter File Output Type 4

Type 4 files are Type 1 files with the invalid tag detections removed.

Example Type 4 output file names:

```
SR24102_241027_110701_Cleaned_Log1_1027_1107_1.csv
SR24102_241027_110701_Cleaned_Log1_1027_1107_2.csv
SR24102_241027_110701_Cleaned_Log2_1027_1110_1.csv
SR24102_241027_110701_Cleaned_Log2_1027_1110_2.csv
.
.
.
```

## 5.5 Filter File Output Type 5

Example Type 5 output file names:

```
SR24102_241027_110701_summary_Log1_1027_1107_1.csv
SR24102_241027_110701_summary_Log1_1027_1107_2.csv
SR24102_241027_110701_summary_Log2_1027_1110_1.csv
SR24102_241027_110701_summary_Log2_1027_1110_2.csv
.
.
.
```

Type 5 files have the synopsis of data contained in the earlier files.

													Period Info					
										Accepted Range		Sig Str						
1	2	3	4	5	6	7	8	9	10	11	12	13	14	15	16	17	18	19
First Date/Time	Last Date/Time	Elapsed (secs)	Tag Code	Det Num	Nominal	Ave	Est	Smallest	Largest	Ave	Min Allowed	# Filtered						
4	11/01/2017 13:06:21.099144	11/01/2017 13:32:59.375030	1611.19 G725B1CCA	277	2	5.79	2.14	1.967	4.306	217	130	2						
5	11/01/2017 13:06:19.543759	11/01/2017 13:32:24.378066	1564.83 G72508686	261	2	6.01	2.22	2.21	4.439	208	130	2						
6	11/01/2017 13:06:19.832399	11/01/2017 13:32:28.110076	1568.28 G72B2C0F9	208	3	7.58	3.07	2.069	3.084	220	130	0						
7	11/01/2017 13:06:19.918855	11/01/2017 13:32:31.673986	1571.76 G7207F739	241	2	6.54	2.07	1.902	2.086	195	130	1						
8	10/30/2017 16:52:34.328983	11/12/2017 01:09:10.138764	1066747.67 G726B5B22	3933*	5	233.74*	5.06	5	5.097	216	130	41						
9	11/10/2017 19:39:09.111642	11/10/2017 19:39:09.111642	43977 G7204AF75	289	2	2.57	2.12	1.938	3.119	194	130	8						
10	10/30/2017 16:52:36.498941	11/12/2017 01:09:18.338041	1066781.49 G7222226F	135344	5	7.52	5.22	3.337	5.284	218	130	945						
11	10/30/2017 17:01:27.262194	11/12/2017 01:09:22.286429	1066794.26 G72AB68CA	108540	5	8.86	5.06	4.523	5.096	219	130	64						
12	11/09/2017 17:14:22.885377	11/09/2017 17:40:30.429007	1567.54 G723F38E9	190	2	8.29	2.13	1.956	4.258	201	130	8						
13	10/30/2017 16:52:33.319613	10/30/2017 17:18:28.108353	1562.91 G726B5B22	158	5	7.52	5.22	3.337	5.284	218	130	1						
14	11/11/2017 23:47:25.919664	11/11/2017 01:13:28.307445	1562.39 G720F5402	125	2	12.6	2.22	1.988	4.354	210	130	0						
15	11/10/2017 12:56:26.323365	11/10/2017 13:22:28.069979	1562.31 G72373103	246	2	6.38	2.11	1.966	2.119	193	130	0						
16	11/10/2017 02:32:42.384258	11/10/2017 02:58:32.074902	1561.75 G72A9CF77	119	3	6.01	2.98	1.995	2.117	185	130	2						
17	10/30/2017 16:50:34.236942	10/30/2017 17:16:32.686552	1558.45 G72517C48	179	2	3.41	2.11	1.938	2.062	181	130	4						
18	11/11/2017 13:24:22.324372	11/11/2017 13:50:29.642380	1567.32 G72F9DF9D	288	2	5.46	2.14	2.127	4.297	216	130	1						
19	11/11/2017 21:45:22.801260	11/11/2017 22:01:58.862047	1596.06 G7248905C	335	2	2.53	2.07	1.933	3.069	206	130	4						

Figure 5-4

<b>Column Name</b>	<b>Description</b>
First Date/Time	Date and Time of first acquisition of the listed Tag Code. Date recorded as mm/dd/yyyy. Time of detection, defined as the time the signal arrives at the hydrophone (TOA) and shall be recorded with microsecond precision (hh:mm:ss.ssssss)
Last Date/Time	Date and Time of last acquisition of the listed Tag Code. Date recorded as mm/dd/yyyy. Time of detection, defined as the time the signal arrives at the hydrophone (TOA) and shall be recorded with microsecond precision (hh:mm:ss.ssssss)
Elapsed	Time difference in seconds between the first two columns.
Tag Code	9-digit tag code as decoded by receiver (e.g., "G7229A8BE")
Det Num	The number of valid detections for the listed tag code. If an "*" is present the Tag Code was filtered out as a false positive.
Nominal	The assumed programmed value for the tag codes' pulse rate interval.
Ave	The average PRI value. An adjacent "*" indicates it was > 7 periods long.
Est	The estimated PRI value.
Smallest	The smallest PRI that was a valid value. The PRIs checked off in the File Data dialog are used to determine the set of acceptable PRIs.
Largest	The largest PRI that was a valid value. The PRIs checked off in the File Data dialog are used to determine the set of acceptable PRIs.
Sig Str Ave	The average signal strength of the valid data for the listed tag code.
Min Allowed	Lower Signal strength values are filtered out.
# Filtered	Number of acquisitions for the listed tag code that have been filtered out.

Table 5-5



## 5.6 Additional Output for Temperature and Depth Tags

When the filter is done running there will be the same output as with running without the temperature depth tag option selected with a few additions.

One additional file type...

Type 6) SR24102\_241027\_110701\_SensorTagData\_Log1\_1027\_1107\_2.csv

And additions to the following file types...

Type 2) SR24102\_241027\_110701\_DData\_Log1\_1027\_1107\_2.csv

Type 4) SR24102\_241027\_110701\_Cleaned\_Log1\_1027\_1107\_2.csv

Type 5) SR24102\_241027\_110701\_summary\_Log1\_1027\_1107\_2.csv

### 5.6.1 Data Appended to Filter File Output Type 2

The following is an example of the data appearing as additional columns appended to the dataset after the column labeled “Notes”.

	AE	AF	AG	AH	AI	AJ	AK	AL	AM	AN
1	Notes	SensorTag	TempDateTime	TempSensorCode	TagTemp(C)	DepthDateTime	DepthSensorCode	TagPress(mBar)	TagDepth(m)	SensorPrd
2		D			0	07/11/2017 05:55:25.226268	G720B60E6	1164.8	1.56	0.082
3		Y			0			0	0	0
4		T	07/11/2017 05:56:25.269162	G7209C264	24.98			0	0	0.082
5		Y			0			0	0	0
6		T	07/11/2017 05:56:49.998400	G7209C264	24.98			0	0	0.082
7		Y			0			0	0	0
8		D	07/11/2017 06:40:06.047076	G7209C5E7	25.01	07/11/2017 06:40:06.129138	G720B5CFB	1163.2	1.54	0.082
9		D	07/11/2017 06:52:42.785414	G7209C186	24.97	07/11/2017 06:52:42.867471	G720B77F8	1174	1.65	0.082
10		D			0	07/11/2017 06:52:46.402909	G720BDF95	1215.6	2.08	0.082
11		D			0	07/11/2017 06:53:57.151103	G720BF835	1225.6	2.18	0.082
12		Y			0			0	0	0
13		D			0	07/11/2017 07:07:44.832237	G726F39C0	11389.2	105.82	0.0825
14		Y			0			0	0	0
15		Y			0			0	0	0
16		D	07/11/2017 07:11:06.365193	G7209C605	25.02	07/11/2017 07:11:06.447265	G720ED175	1517.2	5.15	0.082
17		Y			0			0	0	0
18		D	07/11/2017 15:38:38.816182	G7209E778	25.35	07/11/2017 15:38:38.898222	G720F0587	1538	5.37	0.082
19		N								

Figure 5-5

<b>Column Name</b>	<b>Description</b>
SensorTag	Character denoting general sensor information as defined below...  N - Detection information is for a non-sensor tag. Y - Detection information is for a sensor tag, but no sensor data was paired with this detection. T – Detection information is for a sensor tag and is paired with temperature data only. D- Detection information is for a sensor tag and is paired with depth data and possibly temperature data.
TempDateTime	Date recorded as mm/dd/yyyy. Time of detection, defined as the time the signal arrives at the hydrophone (TOA) and shall be recorded with microsecond precision (hh:mm:ss.sssss). This timestamp is for the received code imparting a tag’s temperature information.
TempSensorCode	9-digit tag code as decoded by receiver (e.g., “G7207975C”) representing the temperature information.
TagTemp(C)	Temperature (C.CC°). If the temperature sensor is not attached or is malfunctioning it will read “99.99”.
DepthDateTime	Date recorded as mm/dd/yyyy. Time of detection, defined as the time the signal arrives at the hydrophone (TOA) and shall be recorded with microsecond precision (hh:mm:ss.sssss). This timestamp is for the received code imparting a tag’s depth information.
DepthSensorCode	9-digit tag code as decoded by receiver (e.g., “G720B3B1D”) representing the depth information.
TagPress(mBar)	The pressure (PPPP.P) in mBar measured by the sensor tag.
TagDepth(m)	The converted depth position (DDD.DD) in meters measured by the sensor tag.
SensorPrd	The period of the sensor codes in seconds appearing after the primary code.

Table 5-5

## 5.6.2 Data Appended to Filter File Output Type 4

The following is an example of the data appearing as additional columns appended to the data after the column labeled “Threshold”.

L	M	N		O	P	Q		R	S	T
BitPrd	Threshold	Temperature	Date/Time	Temp SensorCode	Tag Temp(C)	Depth	Date/Time	Depth SensorCode	Tag Press(mBar)	Tag Depth(m)
239 28/31	168	07/01/2017 09:09:17.576490		G7207D71A	20.07					
239 29/31	172					07/01/2017 09:09:21.270645		G720BB1EF	1197.2	1.89
239 29/31	169	07/01/2017 09:09:46.501307		G7207D8B9	20.11	07/01/2017 09:09:46.583275		G720BC576	1205.2	1.97
239 28/31	162	07/01/2017 09:09:53.745308		G7207D85B	20.08	07/01/2017 09:09:53.827269		G720B3B1D	1150	1.41
240	164	07/01/2017 09:09:57.367835		G7207D85B	20.08	07/01/2017 09:09:57.449804		G720B4D38	1157.2	1.48
239 28/31	160	07/01/2017 09:10:22.701627		G7207D71A	20.07					
239 29/31	163	07/01/2017 09:10:29.937268		G7207D8B9	20.11	07/01/2017 09:10:30.019251		G720C3E4C	1253.6	2.47
240	161	07/01/2017 09:10:33.555154		G7207D905	20.09	07/01/2017 09:10:33.637132		G720C855E	1282	2.75
240	158	07/01/2017 09:10:37.174338		G7207D85B	20.08	07/01/2017 09:10:37.256328		G720C4AD5	1258.4	2.51
239 29/31	167	07/01/2017 09:10:44.416854		G7207D85B	20.08	07/01/2017 09:10:44.498843		G720C4AD5	1258.4	2.51
240	167	07/01/2017 09:10:48.035584		G7207D905	20.09	07/01/2017 09:10:48.117563		G720C030F	1230	2.22
239 29/31	162									
240	157	07/01/2017 09:20:44.334238		G7207D4F8	20.04	07/01/2017 09:20:44.416218		G720B3A43	1149.6	1.4
239 29/31	162	07/01/2017 09:24:45.814802		G7207D5A6	20.05					
240	164	07/01/2017 09:25:11.084643		G7207D5A6	20.05					
240	164	07/01/2017 09:25:14.716976		G7207D37B	20.03					
239 29/31	159					07/01/2017 09:25:18.423210		G72379D0F	5694.8	47.75
239 28/31	165	07/01/2017 09:25:29.188128		G7207D37B	20.03	07/01/2017 09:25:29.270095		G720A4460	1051.2	0.4
240	165					07/01/2017 09:25:32.885043		G720A4782	1052.4	0.41
240	162									
240	160									

Figure 5-6

<b>Column Name</b>	<b>Description</b>
Temperature Date/Time	Date recorded as mm/dd/yyyy. Time of detection, defined as the time the signal arrives at the hydrophone (TOA) and shall be recorded with microsecond precision (hh:mm:ss.ssssss). This timestamp is for the received code imparting a tag's temperature information.
Temp SensorCode	9-digit tag code as decoded by receiver (e.g., "G7207975C") representing the temperature information.
Tag Temp(C)	Temperature (C.CC°). If the temperature sensor is not attached or is malfunctioning it will read "99.99".
Depth Date/Time	Date recorded as mm/dd/yyyy. Time of detection, defined as the time the signal arrives at the hydrophone (TOA) and shall be recorded with microsecond precision (hh:mm:ss.ssssss). This timestamp is for the received code imparting a tag's depth information.
Depth SensorCode	9-digit tag code as decoded by receiver (e.g., "G720B3B1D") representing the depth information.
Tag Press(mBar)	The pressure (PPPP.P) in mBar measured by the sensor tag.
Tag Depth(m)	The converted depth position (DDD.DD) in meters measured by the sensor tag.

Table 5-6

### 5.6.3 Data Appended to Filter File Output Type 5

This file has only one added column appended to it. It appears after the column labeled "# Filtered". It is labeled "Sensor Tag" and just shows whether the code listed belongs to a sensor tag with the indicator "Y" or "N".

## 5.6.4 Additional Filter File Output Type 6

Example Type 6 output file names:

```
SR24102_241027_110701_SensorTagData_Log1_1027_1107_1.csv
SR24102_241027_110701_SensorTagData_Log1_1027_1107_2.csv
SR24102_241027_110701_SensorTagData_Log2_1027_1110_1.csv
SR24102_241027_110701_SensorTagData_Log2_1027_1110_2.csv
.
.
.
```

Type 6 files have the just the code, temperature and depth data broken down by the time the data was received.

1	Depth Data File: Log1 Part1									
2										
3	Barometric Pressure (mBar): 1011.85277922									
4										
5	Tag Code	Date/Time	Tag Code	Secs	Temperature	Date/Time	TempCode	TempSecs	TempTimeSinceCode	Temp(C)
6	06/30/2017	01:16:41.600622	G724A2D02	15643002						
7	06/30/2017	01:17:14.086836	G724A2D02	15643034	06/30/2017	01:17:14.168803	G7207BC5F	15643034.17	0.081967	19.8
8	06/30/2017	01:24:16.680182	G724A2D02	15643457	06/30/2017	01:24:16.762180	G7207BA82	15643456.76	0.081998	19.78
9	06/30/2017	01:24:27.522386	G724A2D02	15643468	06/30/2017	01:24:27.604386	G7207B960	15643467.6	0.082	19.77
10	06/30/2017	01:24:52.805730	G724A2D02	15643493						
11	06/30/2017	01:25:03.638337	G724A2D02	15643504	06/30/2017	01:25:03.720328	G7207B31E	15643503.72	0.081991	19.71
12	06/30/2017	07:10:57.073049	G724BA92B	15664257						
13	06/30/2017	07:11:23.040679	G724BA92B	15664283						
14	06/30/2017	07:11:49.024947	G724BA92B	15664309	06/30/2017	07:11:49.103607	G7207F878	15664309.1	0.078659998	20.4
15	06/30/2017	07:12:08.513317	G724BA92B	15664329						
16	06/30/2017	09:38:28.186755	G724A2D02	15673108						
17	06/30/2017	09:38:42.649346	G724A2D02	15673123						
18	06/30/2017	09:38:57.129631	G724A2D02	15673137	06/30/2017	09:38:57.211621	G7207975C	15673137.21	0.08199	19.43
19	06/30/2017	20:58:43.964329	G724995A7	15713924	06/30/2017	20:58:44.045627	G72088E45	15713924.05	0.081297999	21.9
20	06/30/2017	20:58:50.780835	G724995A7	15713931	06/30/2017	20:58:50.862171	G72088B7A	15713930.86	0.081336001	21.87

Figure 5-7

<b>Column Name</b>	<b>Description</b>
Tag Code Date/Time	Date recorded as mm/dd/yyyy. Time of detection, defined as the time the signal arrives at the hydrophone (TOA) and shall be recorded with microsecond precision (hh:mm:ss.ssssss)
TagCode	9-digit tag code as decoded by receiver (e.g., "G7229A8BE")
Secs	A decimal representation in seconds of the time the primary code was decoded.
Temperature Date/Time	Date recorded as mm/dd/yyyy. Time of detection, defined as the time the signal arrives at the hydrophone (TOA) and shall be recorded with microsecond precision (hh:mm:ss.ssssss) . This timestamp is for the received code imparting a tag's temperature information.
TempCode	9-digit tag code as decoded by receiver (e.g., "G7207975C") representing the temperature information.
TempSecs	A decimal representation in seconds of the time the temperature code was decoded.
TempTimeSinceCode	The elapsed decimal time that has elapsed since the primary sensor tag's code was detected.
Temp(C)	Temperature (C.CC°). If the temperature sensor is not attached or is malfunctioning it will read "99.99".

Table 5-7

1						
2						
3						
4						
5	Depth Date/Time	DepthCode	DepthTimeSinceCode	DepthTimeSinceTemp	Press(mBar)	Depth(m)
6						
7						
8						
9						
10						
11	06/30/2017 01:25:03.802324	G720FC12C	0.163987001	0.081996001	1613.2	6.13
12						
13						
14						
15						
16						
17	06/30/2017 09:38:42.813315	G720B2723	0.163969001		1142	1.33
18						
19	06/30/2017 20:58:44.126930	G720CDD47	0.162601	0.081303	1317.2	3.11
20	06/30/2017 20:58:50.943501	G720B3B1D	0.162666	0.081329999	1150	1.41

Figure 5-8

Column Name	Description
Depth Date/Time	Date recorded as mm/dd/yyyy. Time of detection, defined as the time the signal arrives at the hydrophone (TOA) and shall be recorded with microsecond precision (hh:mm:ss.ssssss) . This timestamp is for the received code imparting a tag’s depth information.
DepthCode	9-digit tag code as decoded by receiver (e.g., “G720B3B1D”) standing for the depth information.
DepthTimeSinceCode	The elapsed decimal time that has elapsed since the primary sensor tag’s code was detected.
DepthTimeSinceTemp	The elapsed decimal time that has elapsed since the temperature sensor tag’s code was detected.
Press(mBar)	The pressure (PPPP.P) in mBar measured by the sensor tag.
Depth(m)	The converted depth position (DDD.DD) in meters measured by the sensor tag.

Table 5-8

## **6.0 Triton's Remote Communicator - Remote Offload Tool**

Triton's Remote Communicator (TRC) facilitates remotely retrieving data from the SR3017 by simplifying the pushing and pulling of data from the stored data files. This is done via a PC's serial port or a TCP/IP (internet) connection. This works through the RS232 serial port shown in Figure 1-1. Triton's Remote Communicator software is ideally set up to work with the Sierra Wireless Airlink RV50 cellular modem, a modem with serial RS232 to WIFI Converter or to directly connect to a PC's serial com port. The software can be downloaded from our website and is compatible with Windows 7, Windows 10 and Windows 11 operating systems. After downloading the software click on the setup executable and follow the instructions.

### **6.1 Main Command Window**

The first screen that appears when the software is run is shown below:

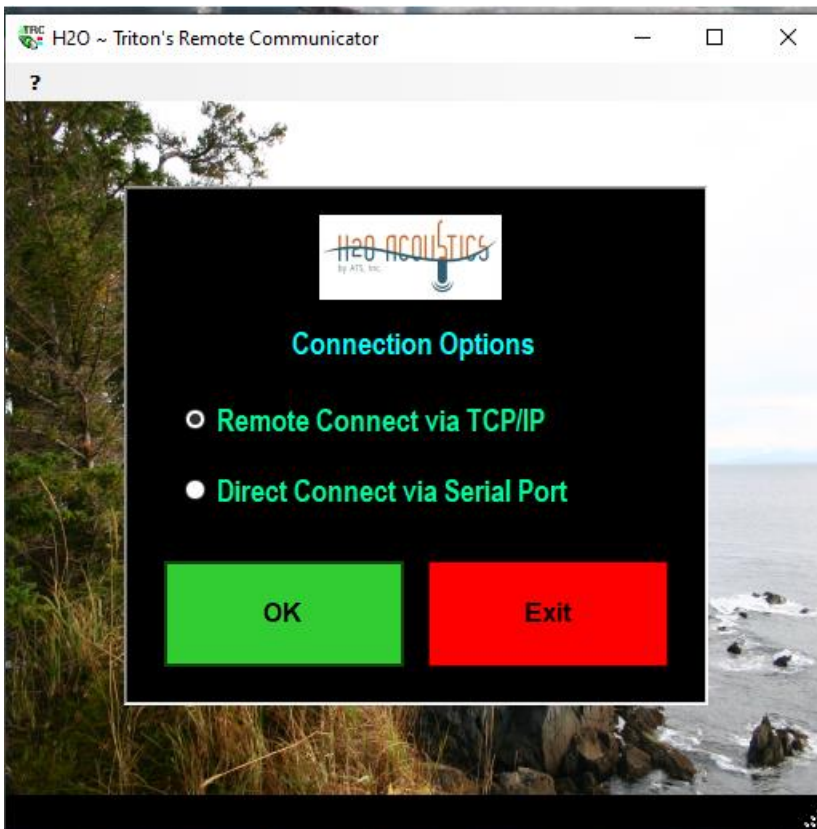

Figure 6-1



## 6.2 Remote Connect via TCP/IP

Select this choice if you are planning to use the Sierra Wireless RV50 modem or a serial RS232 to WIFI Converter.

### 6.2.1 Sierra Wireless RV50 Modem Configuration Settings

When configuring your modem, you need to set it up to allow two way communication with the SR3017 via the RS232 serial port. This can be done using Sierra Wireless's ALEOS software. You'll need to set it up for Reverse Telnet/SSH.

To do this ...

- 1.) Connect via the RV50 modem via an Ethernet cable to a PC.
- 2.) Log into the ALEOS software by entering <http://192.168.13.31:9191> from your Web browser.
- 3.) User Name: user and Password:12345 **Log In**
- 4.) Select Tab <Serial> then option <Port Configuration>.
- 5.) In the Startup Mode Default field, select Reverse Telnet/SSH.
- 6.) In the Configure Serial Port field, set the speed, data, parity, and stop bits to 115200,8N1.
- 7.) Go to Services > Telnet/SSH
- 8.) In the Remote Login Server Mode field, select: Telnet.
- 9.) In the Remote Login Server Telnet/SSH Port Timeout(minutes) enter: 255
- 10.)Click Apply
- 11.)Reboot the Airlink gateway
- 12.)Without the Trident Remote Communicator use a Telnet or SSH terminal client such as Putty or Teraterm to connect and verify the connection is working.
- 13.) It should be set to Autologin so use Telnet in a specified port. The default TCP port# is 12345. On logging in a Welcome screen will be displayed followed by settings ending with the text "Terminal ready".
- 14.)If the SR3017 is connected to the RV50 and running correctly you will be able to see run status messages and communicate via the command prompt.

## 6.2.2 Telnet Screen

Once your Sierra cellular modem or modem with serial RS232 to WIFI Converter is configured enter **OK**. Each modem will have a different static IP address assigned to it. Enter that in the IP address field along with the Tcp port and other pertinent sign in information.

The screenshot displays the 'Station Sign In and Status Info' window. It features a table with columns for Station Description, IP Address, Tcp Port, User Name, Pswd, Hourly, Daily, CR, Serial #, Last Contact, File Cnt, Volts, Message, and + Sync. Below the table are three buttons: 'Get Directory' (green), 'Start Unattended Logging' (teal), and 'Close' (red). A 'Disconnected' status bar is visible at the bottom.

Station Description	IP Address	Tcp Port	User Name	Pswd	Hourly	Daily	CR	Serial #	Last Contact	File Cnt	Volts	Message	+ Sync
Station 1	126.254.23.26	25246			<input checked="" type="checkbox"/>	<input type="checkbox"/>	<input type="checkbox"/>	23082	1/30/2024 12:03	5	99.9	NO OPS	<input checked="" type="checkbox"/>
Station 5	192.159.0.114	5895			<input checked="" type="checkbox"/>	<input type="checkbox"/>	<input type="checkbox"/>	20007	1/30/2024 12:12	11	12.37	SERVICE NEEDED	<input checked="" type="checkbox"/>
Station 2	192.169.0.115	5895			<input checked="" type="checkbox"/>	<input type="checkbox"/>	<input checked="" type="checkbox"/>	20086	1/26/2024 8:05	8	12.62	Log In Failed	<input checked="" type="checkbox"/>
					<input type="checkbox"/>	<input type="checkbox"/>	<input type="checkbox"/>						<input type="checkbox"/>
					<input type="checkbox"/>	<input type="checkbox"/>	<input type="checkbox"/>						<input type="checkbox"/>

Figure 6-2

## 6.2.2.1 Get Directory

If you want to view the names of the files you have on your SDHC card, click the **Get Directory** button.

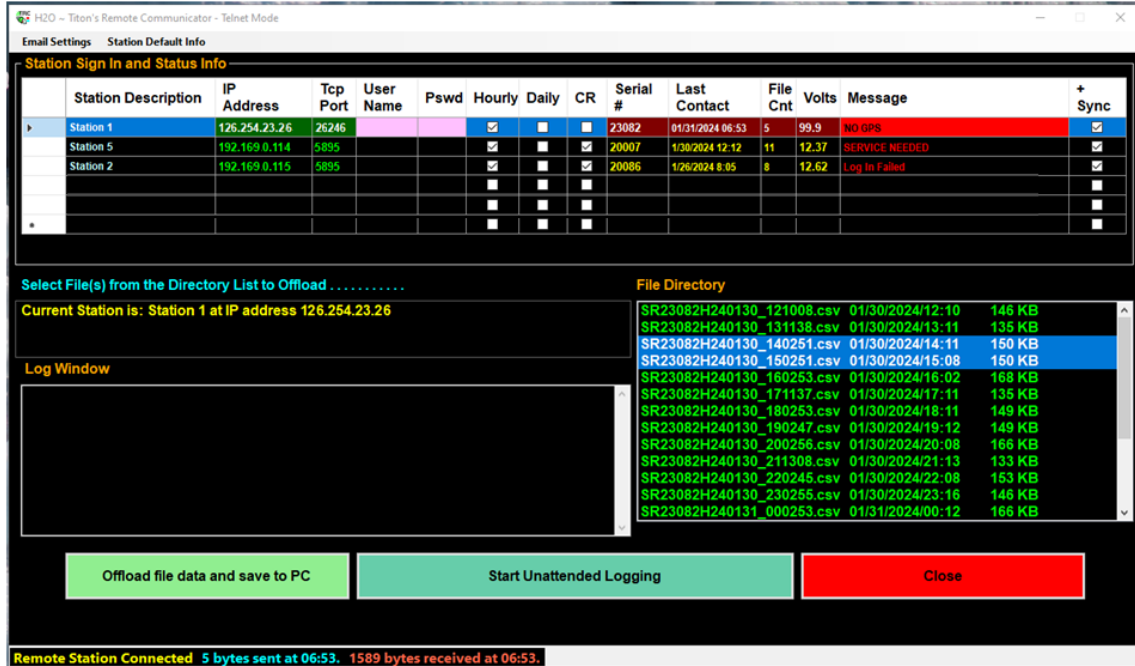

Figure 6-3

## 6.2.2.2 Offload File Data And Save To PC

To pull the desired files from the SDHC card and copy them to the C:\Advanced Telemetry Systems, Inc\H2O *Triton* Receiver\Data” of your PC ...

- 1) Highlight the desired filenames in the File Directory list box.
- 2) Click on the button labeled **Offload file data and save to PC**.

### 6.2.2.3 Station Default Info

Parameters used for filling in a new station entry or used during the **Unattended Logging** are set in the Station Default Info screen.

This screen is accessed from the toolbar of the Telnet screen.

Parameters used for auto filling in values for a new station entry are listed below:

1. Tcp Port – Port address the Modem is using for the Transmission Control Protocol (TCP) connection.
2. User Name – User Name required to connect to the station's modem's port.
3. Password– Password required to connect to the station's modem's port.
4. Download Schedule, Hourly or Daily – The Schedule that the TRC will be pulling data from the SR3017. The receiver will be creating files either hourly or daily depending on this setting.
5. Follow each char entry transmit with a CR. – Some modems might require a CR after each transmitted entry. This currently is not required by the Sierra Wireless RV50 Modem.
6. Synchronize the Clocks to GPS satellite time every 5 minutes for precision time (+Sync). – This setting decides if the SR3017 station will be synchronizing its clocks every 5 minutes to GPS or not.

Parameters used to govern **Unattended Logging** are listed below:

1. Hr To Start Downloading – Especially useful for Daily downloads. This specifies what hour the TRC software will start pulling data.
2. Maximum File Size Allowed – The maximum file size allowed for automatic downloading. If the file is larger than this value, it will have to be manually retrieved.
3. Maximum Time Allowed Per File – If it takes longer than this amount of time to automatically download a file, it will quit the download.
4. Low Voltage Warning Trip Value – If the voltage being read is less than this value it will show a warning in the Message column.
5. Data Folder Name – The folder that the downloaded files get copied to.

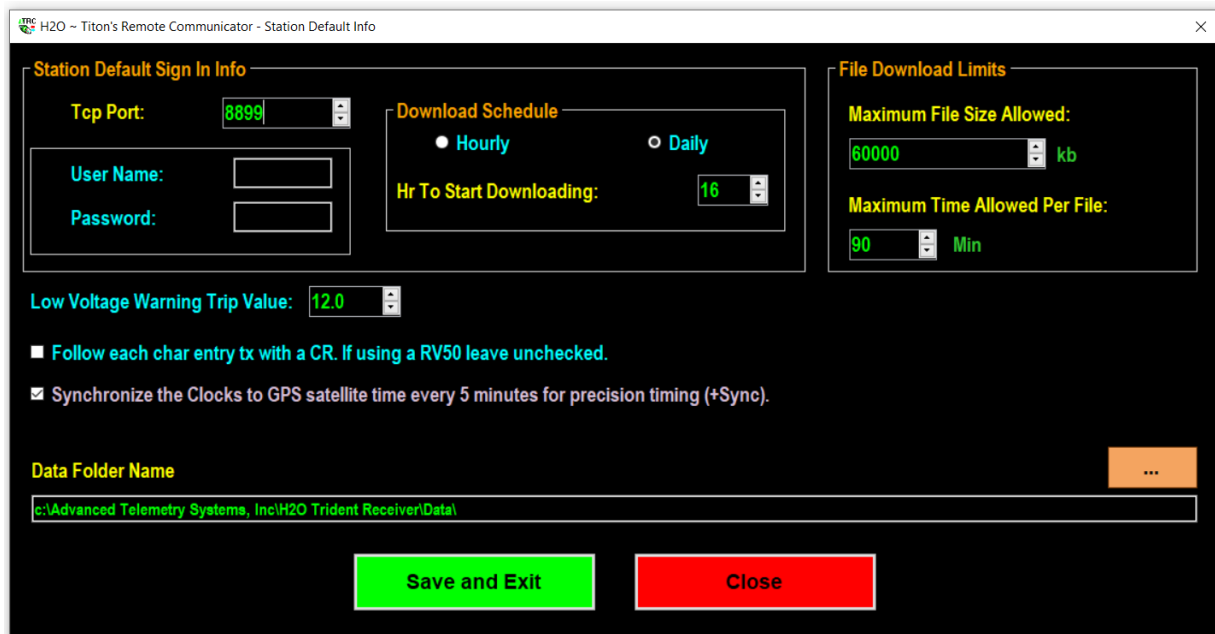

Figure 6-4

## 6.2.2.4 Start Unattended Logging

To have the SR3017 automatically send data to the cellular modem click the **Start Unattended Logging** button.

Once your logging session has been started it will log into the cellular modem just before the start of each hour and retrieve the dump of the data for the previous hour. The data will be saved to “C:\Advanced Telemetry Systems, Inc\H2O Trident Receiver\Data\” in the folder containing the SR3017 unit’s ID as a “csv” file.

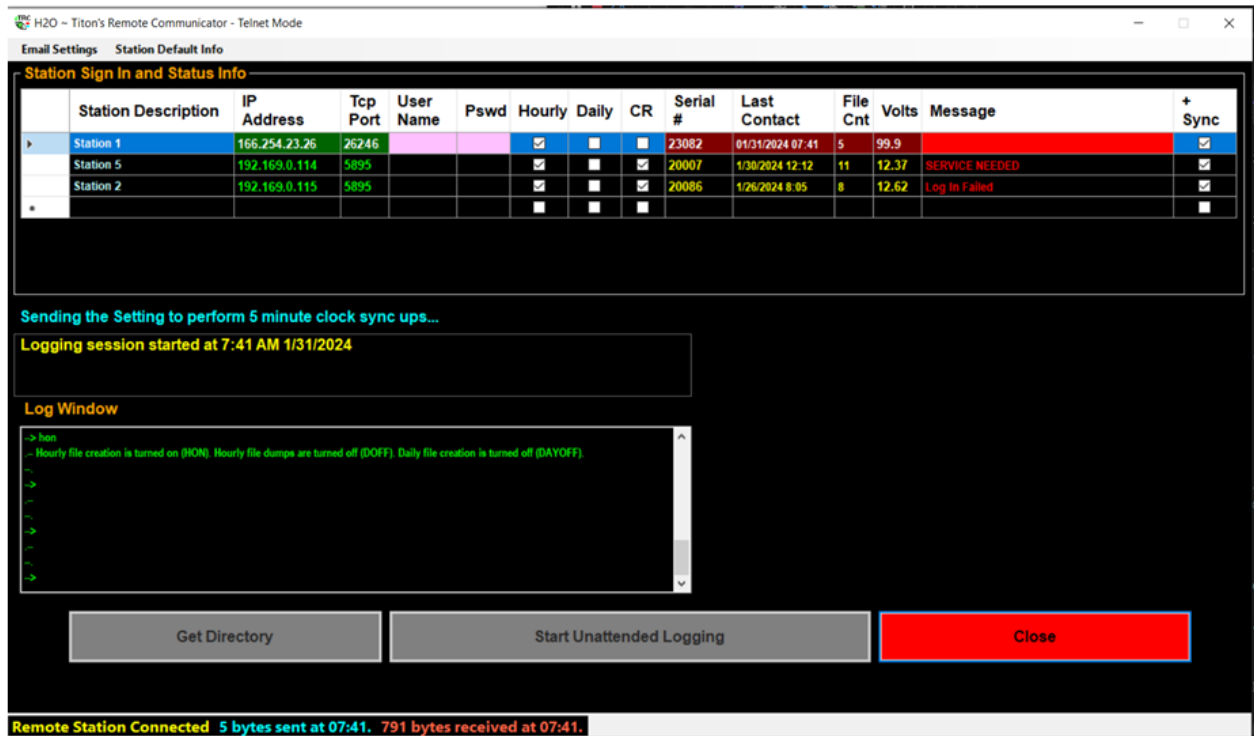

Figure 6-5

The routine starts by sending either 'hon' or 'dayon' commands to the stations in the list, indicated by the selected checkbox.

The Message column will display any error that was gathered during its last station contact. Below, is a list of possible error messages.

1. 'Directory attempt Failed' - The directory command to display the files from the SDHC card failed.
2. 'Login Failed' - The attempt to log into the SR3017 receiver's modem failed.
3. 'Low Voltage' - The SR3017 voltage is lower than the TRC trip value.
4. 'NO GPS' - The SR3017 is not picking up a GPS signal.
5. 'SERVICE NEEDED' - The SR3017 is showing that its signal sensitivity is low.

## 6.3 Direct Connect via Serial Port

Select this choice if you are planning to connect to a Windows device via a RS232 serial port connection.

When you click on the **Direct Connect via Serial Port** you will be prompted for the Com port that has been assigned to your connection.

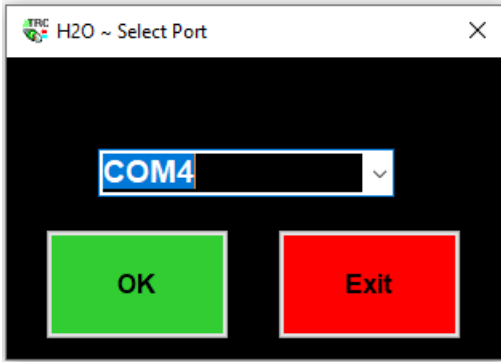

Figure 6-6

### 6.3.1 Get Directory

If you want to view the names of files you have on your SDHC card, click the **Get Directory** button.

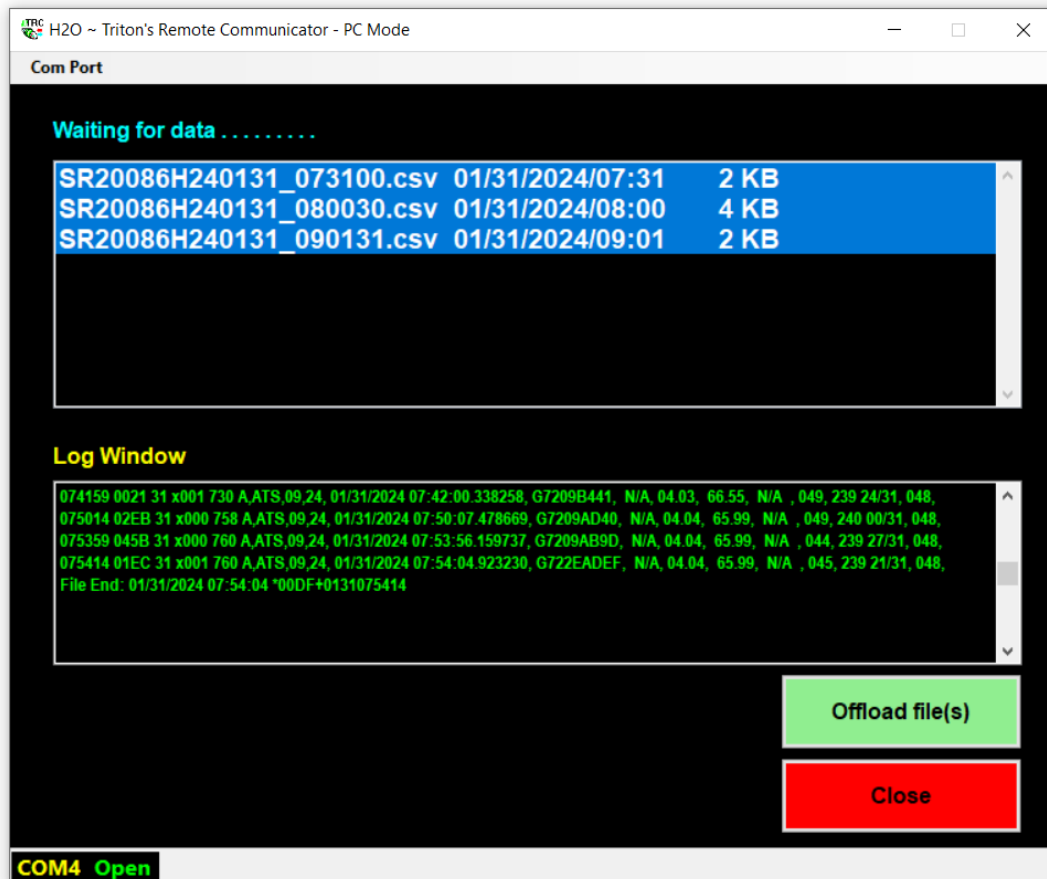

Figure 6-7

## 6.3.2 Offload file(s)

To pull the desired files from the SDHC card and copy them to the C:\Advanced Telemetry Systems, Inc\H2O *Trident* Receiver\Data\” of your PC ...

1. Highlight the desired filenames in the upper list box.
2. Click on the button labeled **Offload file(s)**.

## 7.0 Uart Operating System

The SR3017 Acoustic Receiver has a number of features available via an UART command prompt. The serial port settings are Baud:115200, Data – 8 bit, Parity – none, Stop bits – 1 and no flow control.

The port displays status information for the normal running operation. The Help Menu containing the available options can be accessed when a ‘?’ is entered at the command prompt.

### 7.1 Start-up Message and Help Menu

```
*** SETTINGS AND ID ***
.--
.-- Hourly file creation is turned off (HOFF). Hourly file dumps are turned off (DOFF). Daily file creation is turned off (DAYOFF).
.--
.--
.-- 5 minute drift correction sync ups are turned on.
.--
.--

ATS Sonic Receiver SR3017 Firmware v10.61

DSP v07.90

Serial Number: 22138

*** COMMAND LIST ***
Display Command List:      ?
Show Memory Card Contents: DIR
DIR - Last Page:          DLP
Format Memory card:       FORMAT
Display Contents of File...: TYPE <FILENAME>
Delete File:              DEL <FILENAME>
Hourly File Creation:     HON - New files hourly, HOFF & DAYOFF - Always append to the same file, File dumping optional
Daily File Creation:     DAYON - New files daily, HOFF & DAYOFF - Always append to the same file, No file dumping
```



```
Hourly File Dumps:      DON - New files dumped and created hourly, DOFF - No file dumping
Run Diagnostics & GPS Sync: TEST
Get Current Date/Time:  TIME
Set Current Date/Time:  TSET <MMDDYYHHmmSS>
Change the Time Zone Offset: ZONE <##>
Report GPS Fix every Minute: GPS - Toggles Flag
Turn Off 5 Min Clock Syncs: 5OFF - Turns off 5 minute clock syncs, 5M - Turns them on.
Display Tag Detection Data: DTAG - Toggles Flag
Monitor Clock Drift:     MCD - Toggles Flag
--
.-- Battery voltage is: 04.66  Hourly Detection Count: 27 Total Detection Count: 27 Poor Signal
```

## **8.0 Addendum: Remote Control via Cellular Modem**

### **Description:**

This addendum describes a method for operators of the SR3017 Acoustic Receiver to remotely control the SR3017 when it is equipped with a user-supplied Sierra Wireless RV50 cellular modem.

The addendum was authored by a third party who was under contract to NOAA to design the required circuitry. It provides a wiring schematic and instructions to program an RV50 to control a normally closed relay that powers fish monitoring equipment (SR3017).

Thanks to NOAA Fisheries, Santa Cruz, CA office, for providing this documentation to ATS so it may be shared for use by ATS acoustic equipment operators.

For further information about this documentation, please contact ATS Sales and Service.

## Remote Control via Cellular Modem

### Scope:

Provide wiring schematic and instructions to program an RV50 to control a normally-closed relay that powers fish monitoring equipment (SR3017).

### Procedure:

To control the relay, we suggest using the green (GRN) I/O line to sink current through the relay coil. To remotely control the relay, we recommend logging into the RV50's ACEmanager interface via a public static IP address.

A schematic diagram is provided below as well as information from the manual to remotely control the relay.

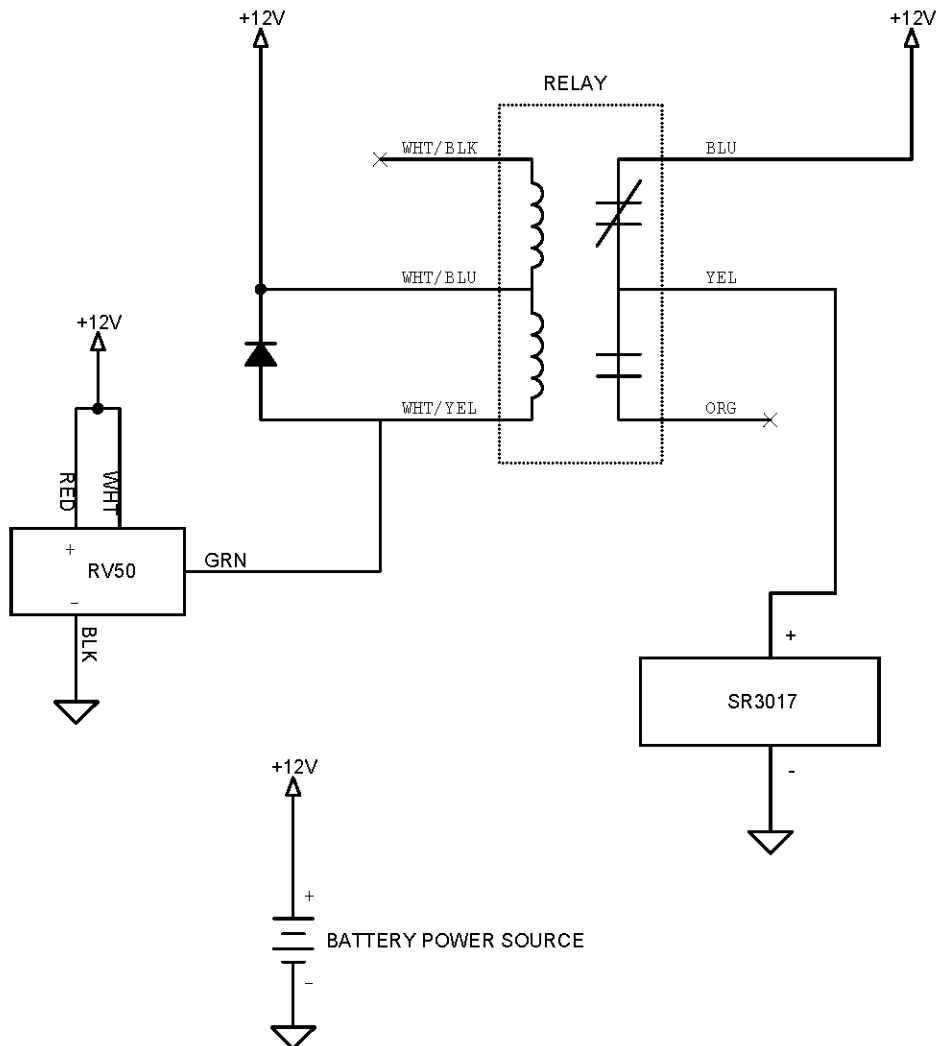

The relay shown is a RIBU1C.

The diode shown is a flyback diode which suppresses the voltage spike that occurs during the removal of the sink current of the RV50. For this diode, we recommend a 1N4007 or equivalent.

It is **CRITICAL** that this diode be inserted correctly as it is polarity sensitive.

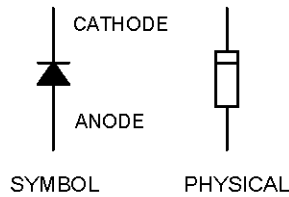

For ACEmanager Logon, make sure that Remote management is enabled. Then log into the unit remotely while it is online to test that you can access ACEmanager. (Change your password from 12345 to a complex one if you haven't done so already!)

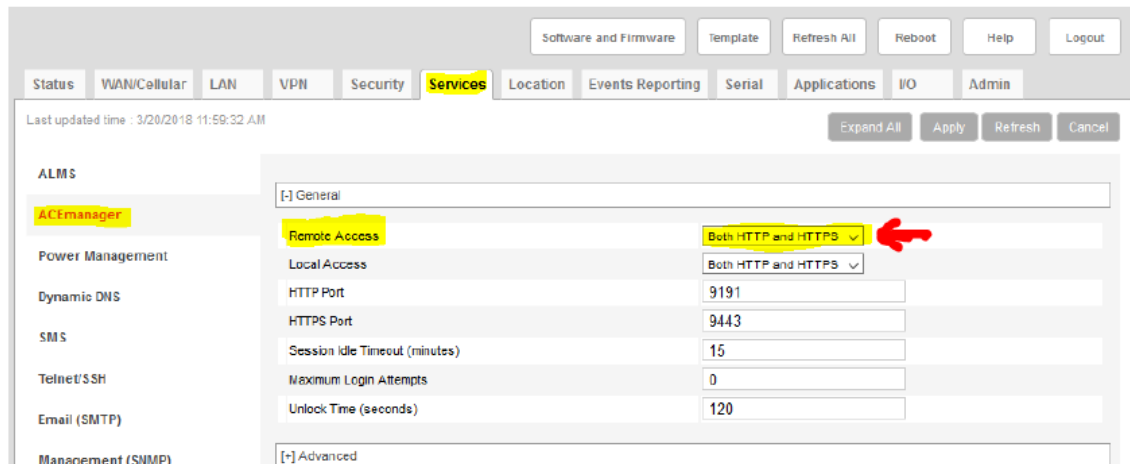

Configure the Relay output to be OFF during initialization: (Click Gray APPLY Button)

The screenshot shows the I/O configuration page. The 'Relay Settings' section contains a table with the following data:

Number	Initial Setting
1	OFF

Relay off – Normal operation (Click gray Apply button if changing. No need to reboot, even though it says so.)

The screenshot shows the I/O configuration page. The 'Relay Output' section contains a table with the following data:

Number	Value (0 - relay open, 1 - relay closed)
1	OFF

Relay on – Removes Power from SR3017 (Click gray Apply button if changing. No need to reboot, even though it says so.)

The screenshot shows the I/O configuration page. The 'Relay Output' section contains a table with the following data:

Number	Value (0 - relay open, 1 - relay closed)
1	Drive Active Low

